

POLITÉCNICA

UNIVERSIDAD POLITÉCNICA DE MADRID

[www.upm.es](http://www.upm.es)



POLITÉCNICA

UNIVERSIDAD POLITÉCNICA DE MADRID

Escuela Universitaria de  
Ingeniería Técnica Aeronáutica

## Helicopters

Professors: Miguel A. Barcala Montejano  
*Ángel A. Rodríguez Sevillano*



UNIVERSIDAD POLITÉCNICA DE MADRID

Escuela Universitaria de  
Ingeniería Técnica Aeronáutica

**STRUCTURE and  
CONFIGURATION OF  
THE HELICOPTER**

POLITÉCNICA





## Approach

- Distinctive Designs.
- Description of the different parts and their fundamental use.







# APPROACH





## GENERAL STRUCTURE

- The Structure or cell (airframe) in a conventional single rotor helicopter is composed of:
  - fuselage,
  - landing gear,
  - tailboom, and
  - cowlings and main transmission.

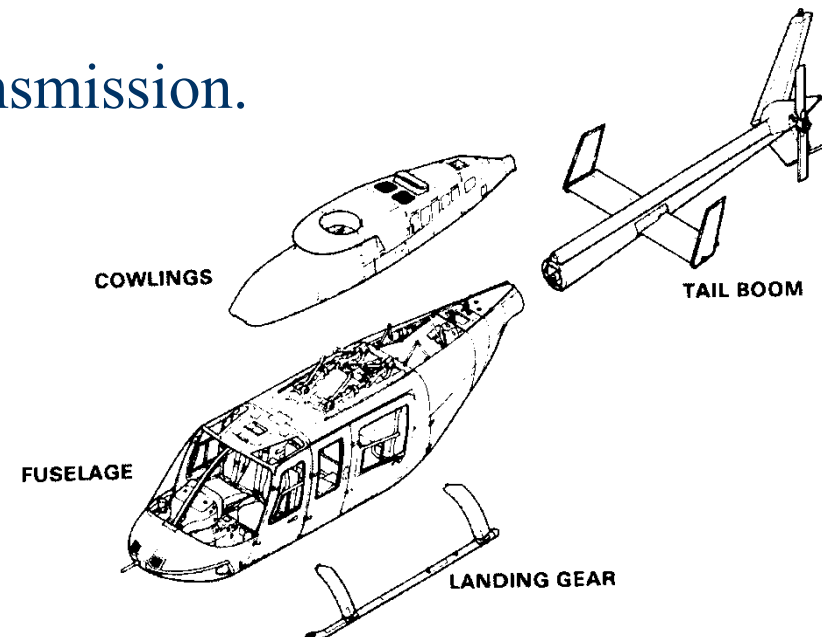



## GENERAL STRUCTURES

- Other examples.

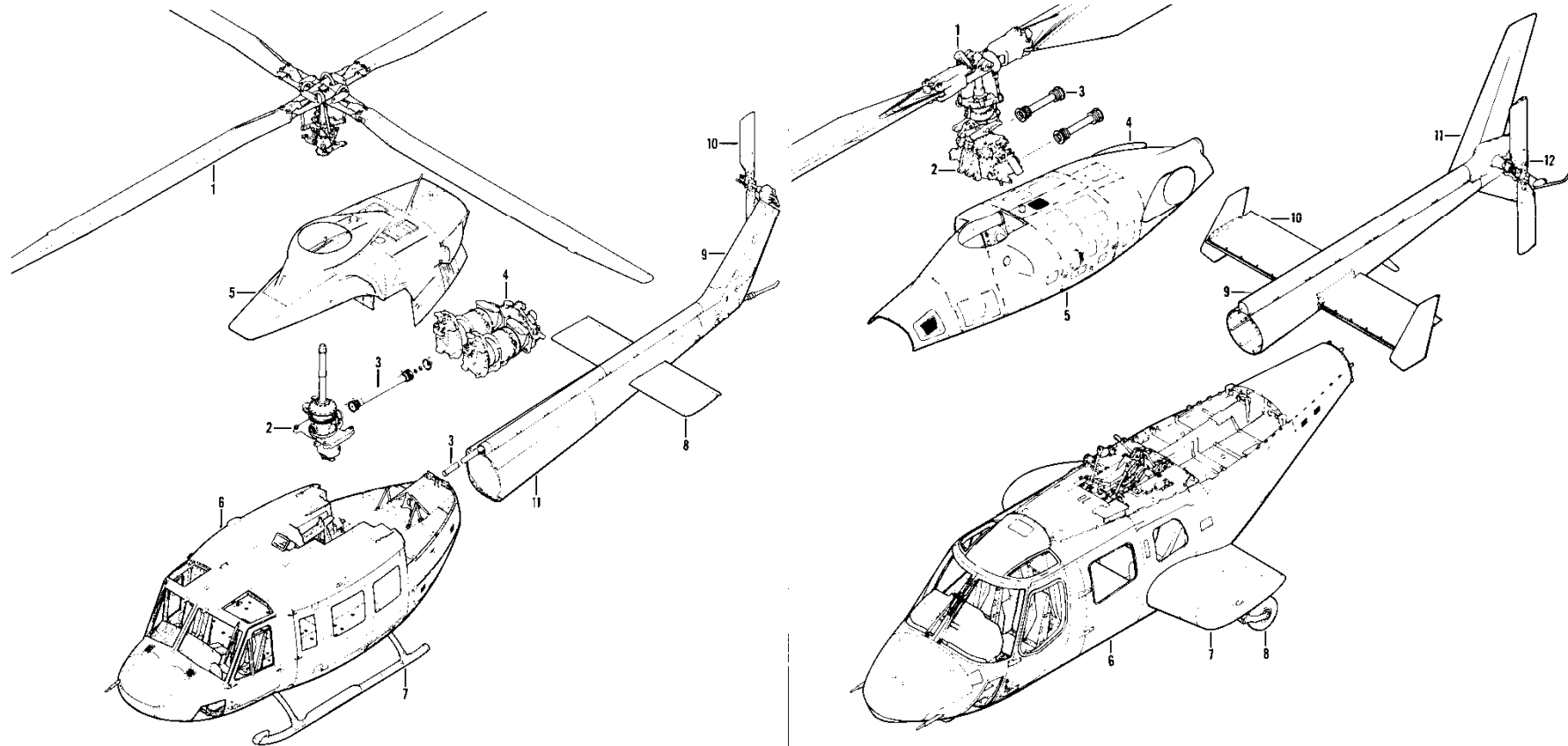



# GENERAL STRUCTURE

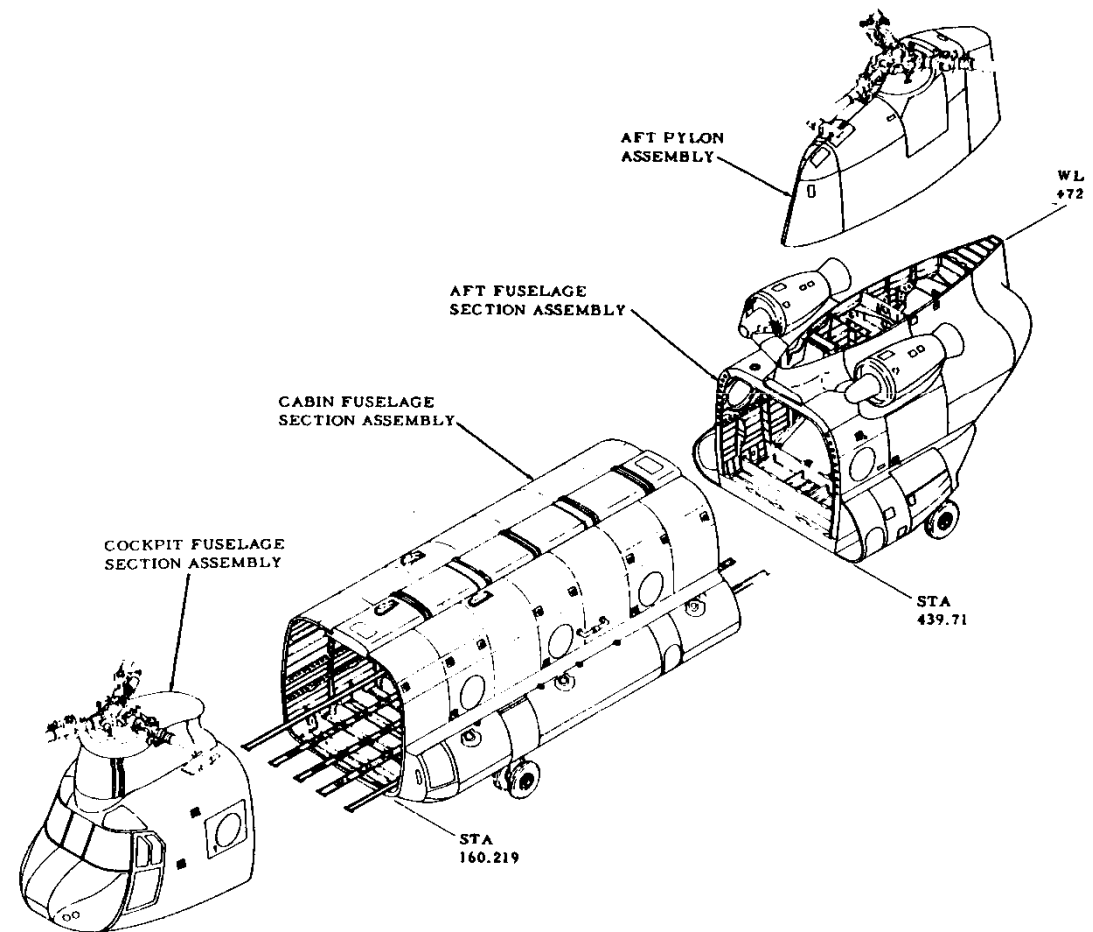





# GENERAL STRUCTURE

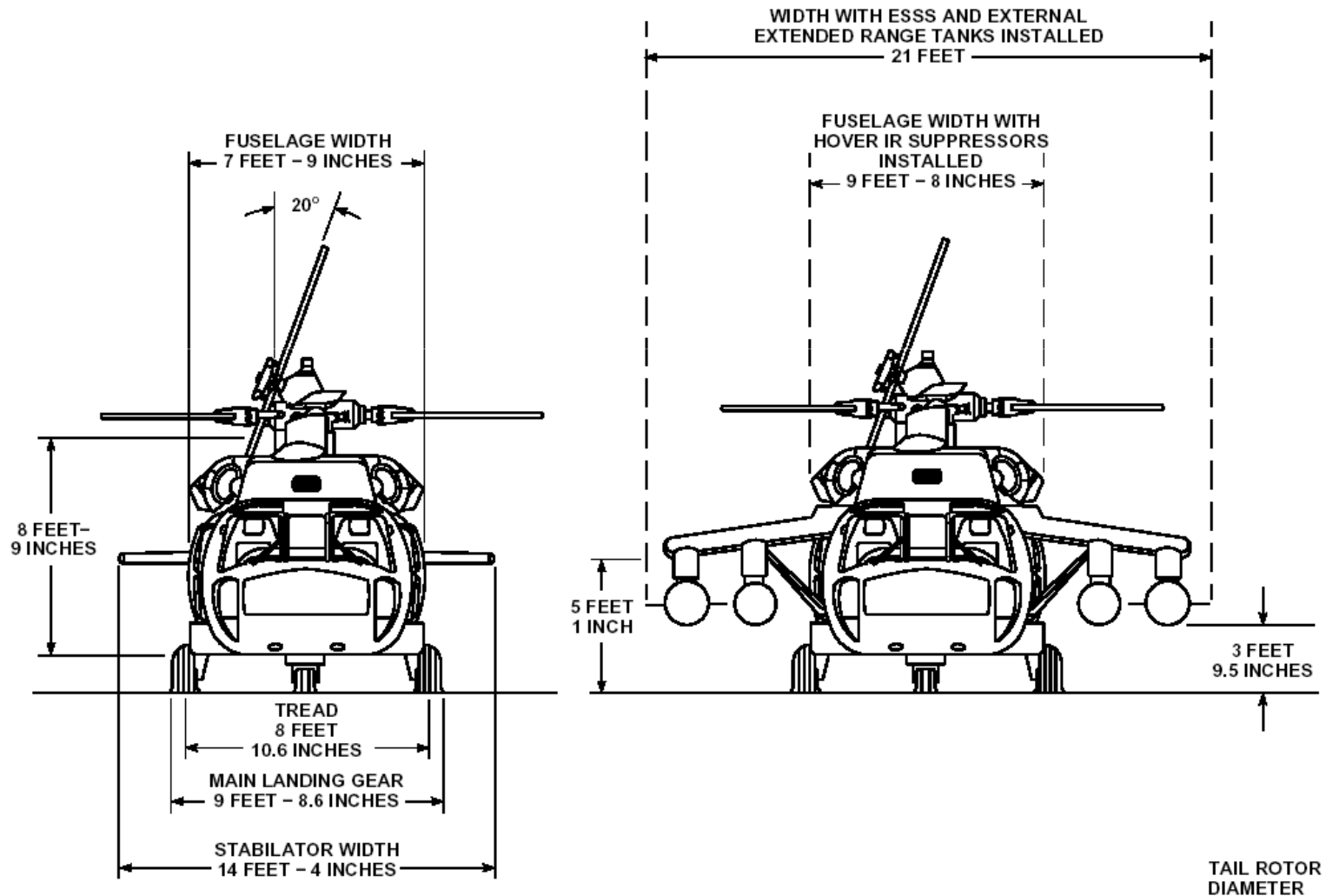



## GENERAL STRUCTURE

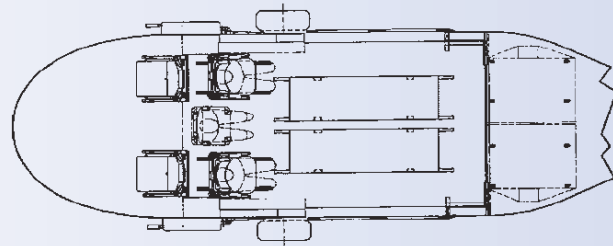

- Casualty Evacuation**
- 6 litters
  - 5 crew

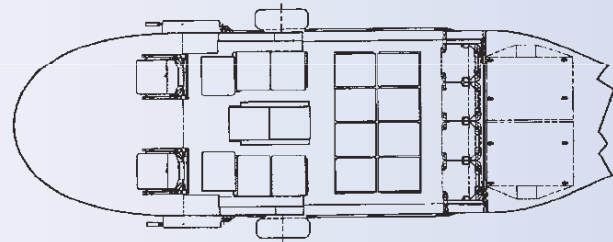

- Troop Transport**
- 15-20 troop seats
  - 2 crew

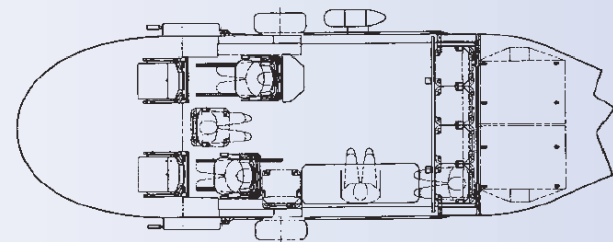

- Search and Rescue**
- 10 rescuees
  - 2 crew



# GENERAL STRUCTURE

## Utility/Offshore Oil Cabin Configuration

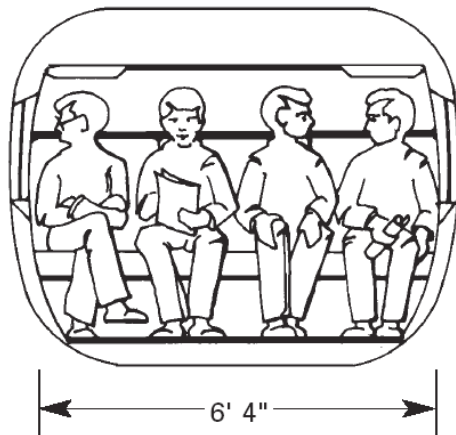
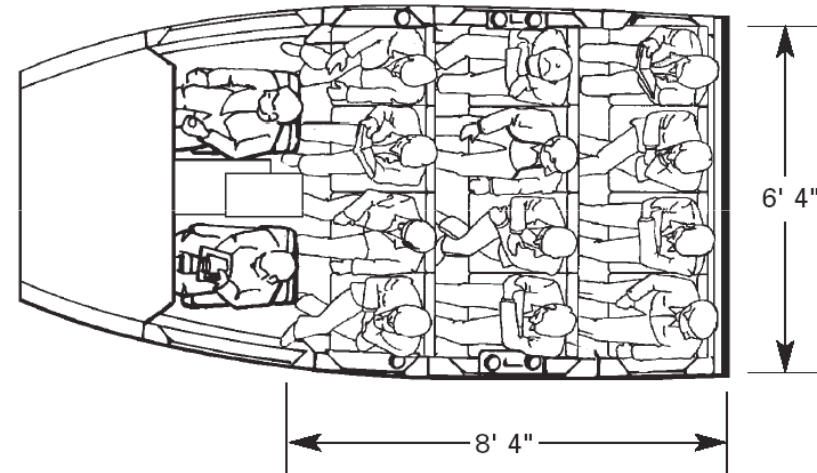
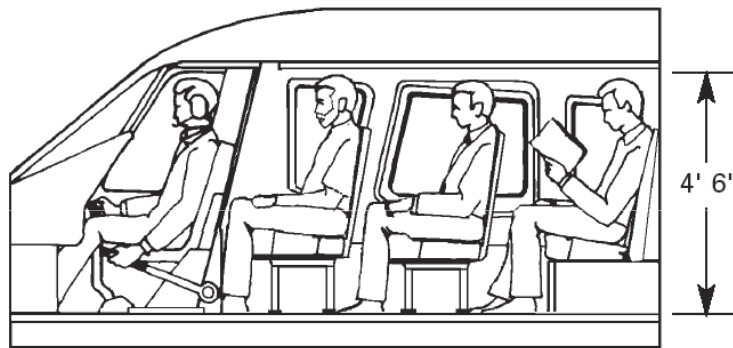

Passenger door width	37.5"
Passenger door height	52.0"





# GENERAL STRUCTURE





# GENERAL STRUCTURE





# GENERAL STRUCTURE

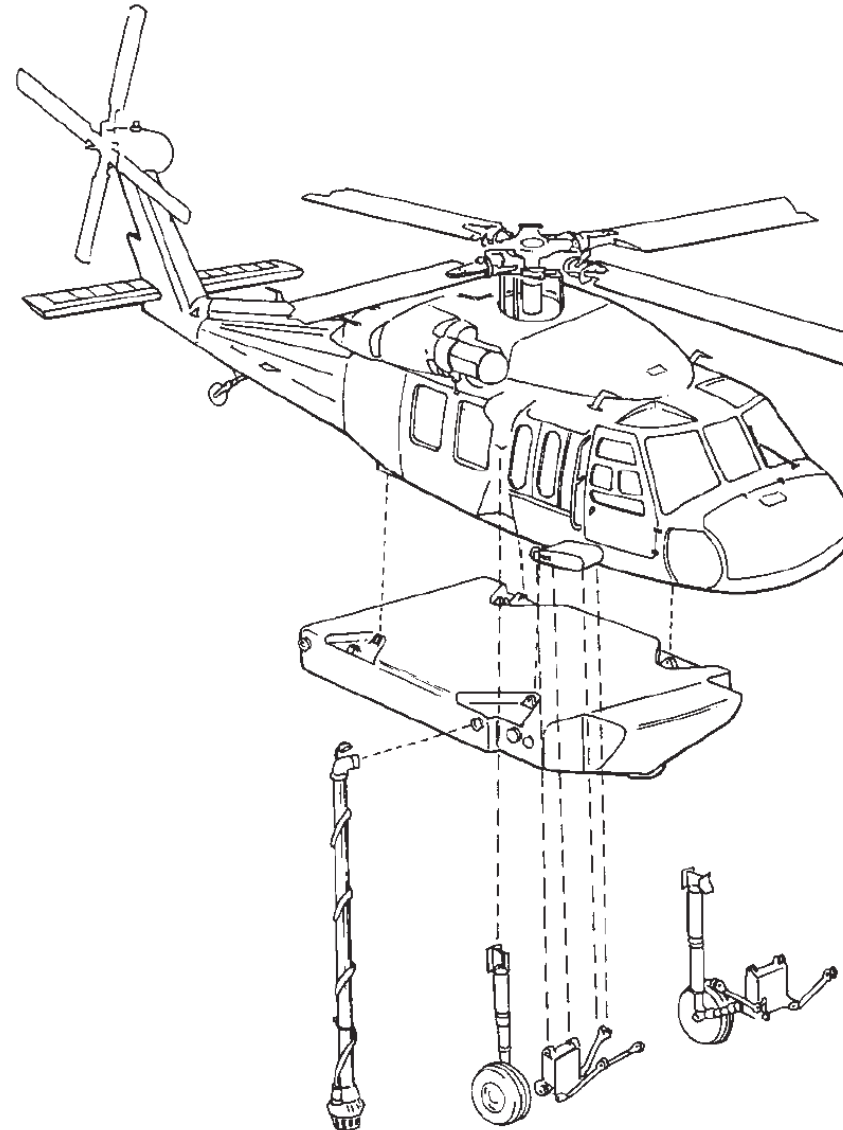





# GENERAL STRUCTURE





# GENERAL STRUCTURE

## MD 600N

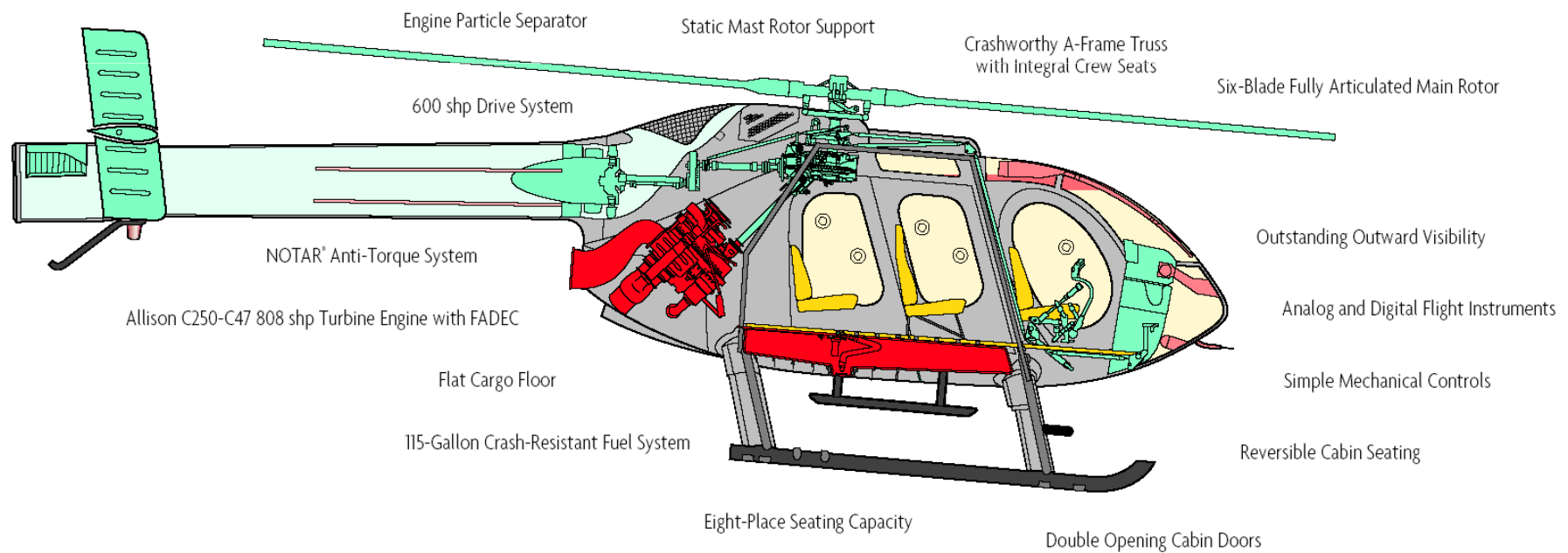



## Fuselage

- Fuselage:

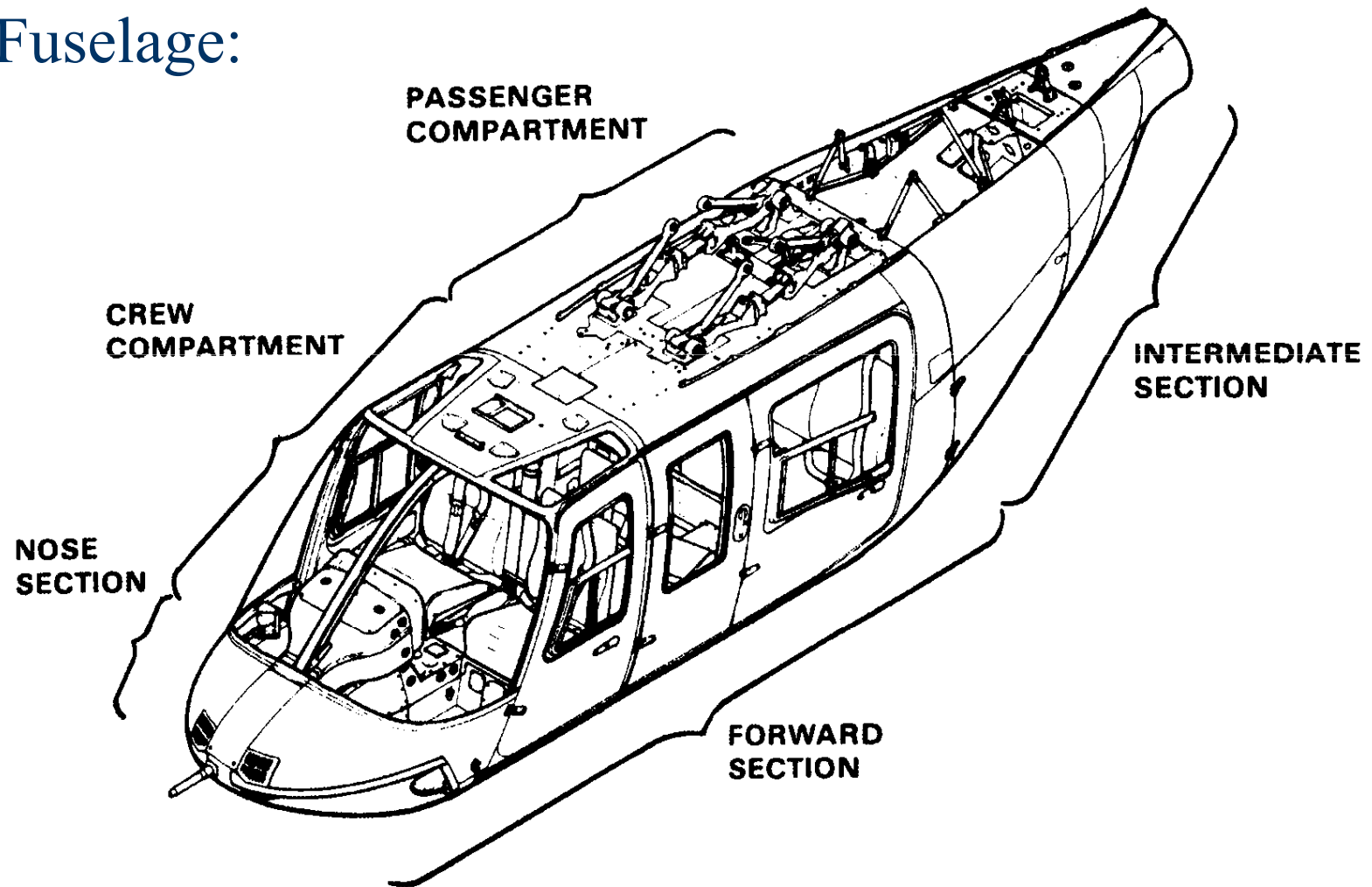





## Fuselage. Forward section

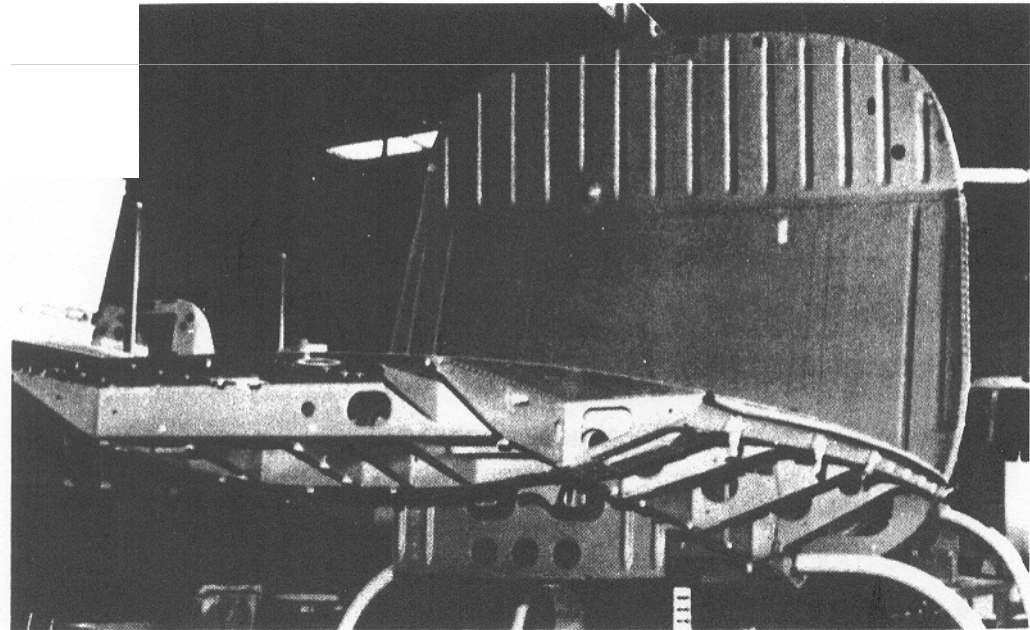
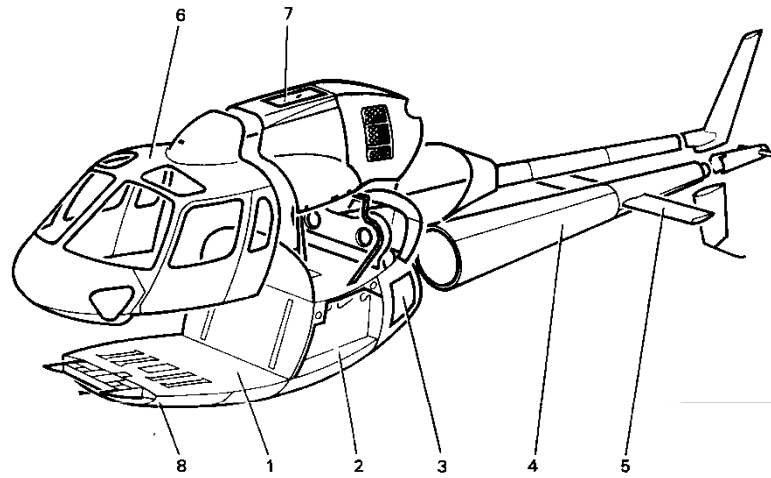



## Fuselage. Forward section

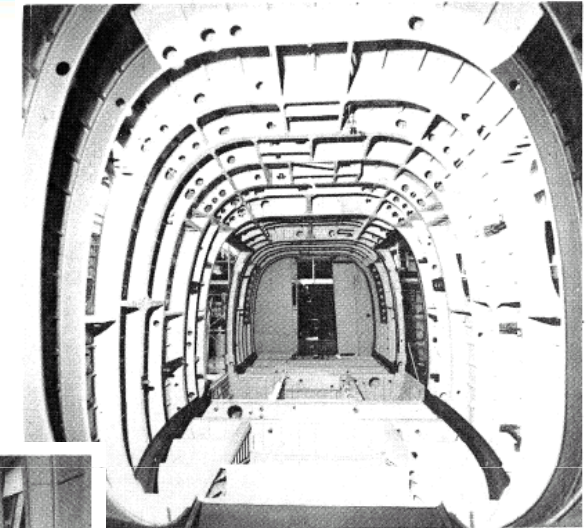
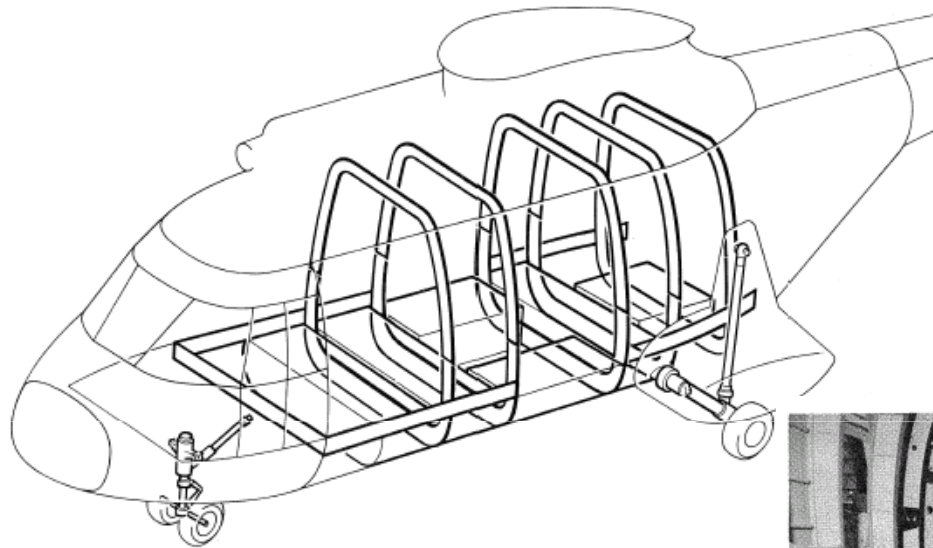

UPPER STRUCTURE

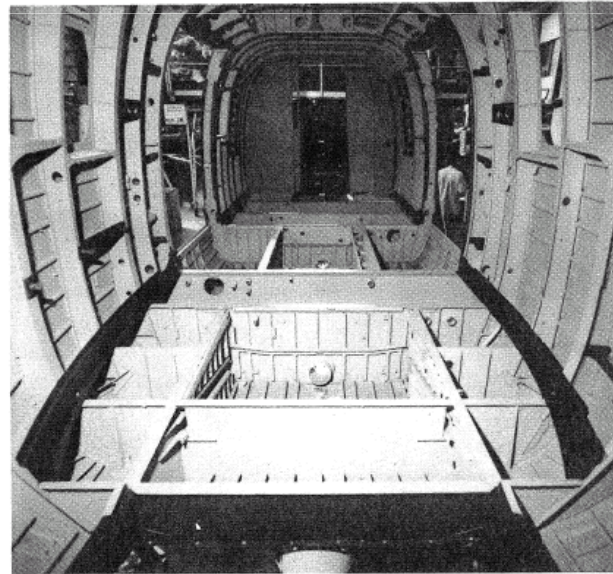

LOWER STRUCTURE





## Fuselage. Forward Section







## Fuselage. Intermediate section

- Usually a semimonocoque structure.
  - Plataform for the engine.
  - Bays for equipment and baggage.

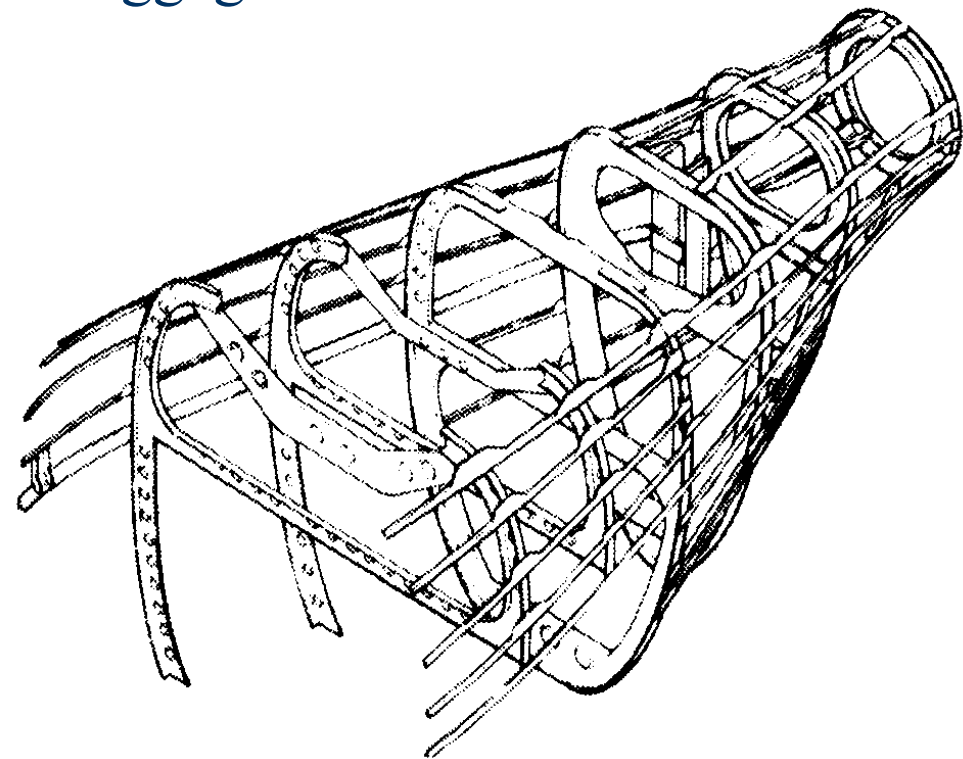



## Fuselage

### Other examples

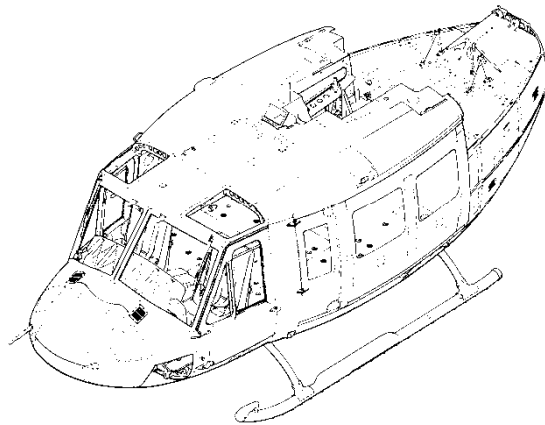

1. Engine cowling
2. Passenger-cargo door
3. Passenger step
4. Landing gear
5. Crew door
6. Windshield wiper
7. Nose compartment window
8. Upper hinged nose door
9. Lower hinged nose door
10. Windshield
11. Crew seat
12. Roof window
13. Transmission cowling

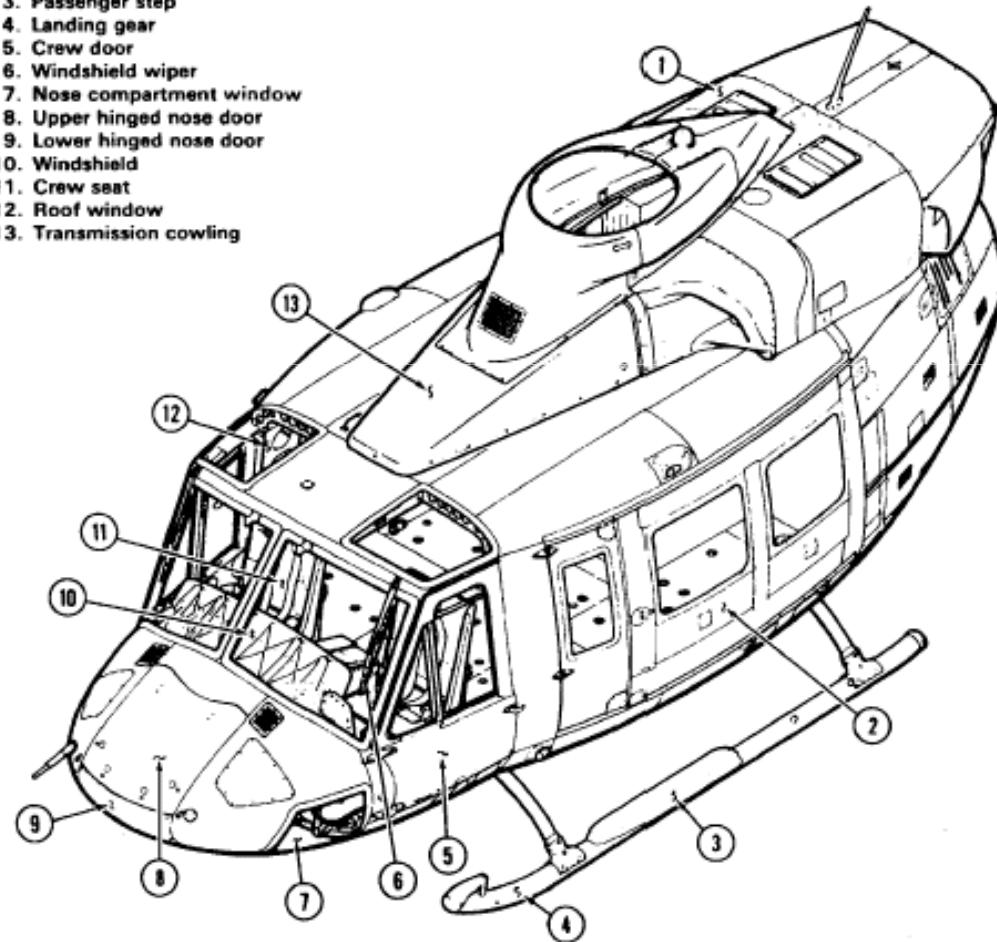

412-M-53-2



## Fuselaje

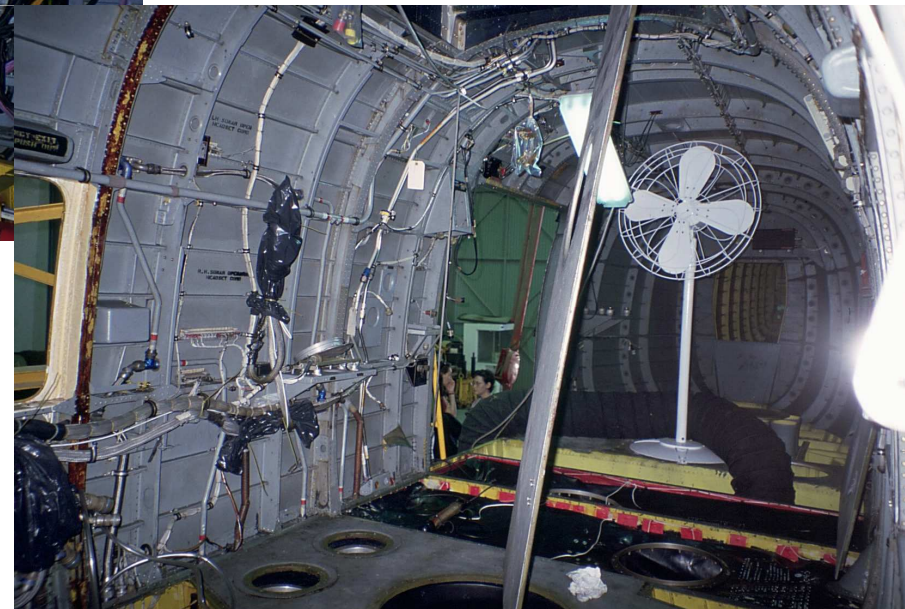





# Fuselage

## ● EC-135.

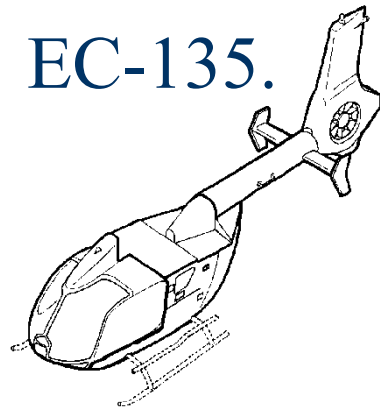

- 1 Cabin Structure
- 2 Main Fuselage
- 3 Rear Structure

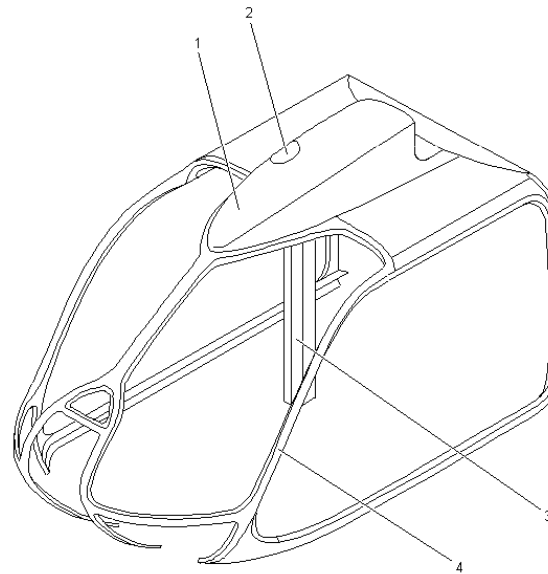
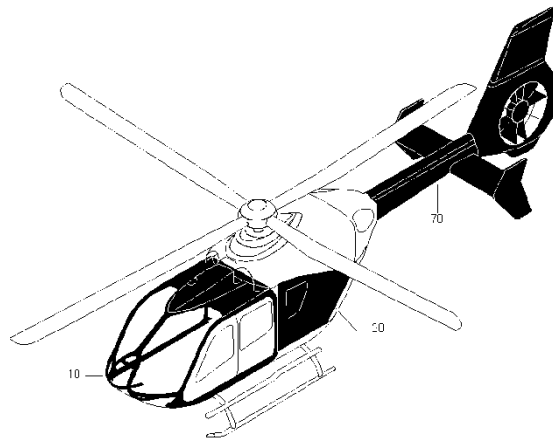

Configuration - Cabin Structure

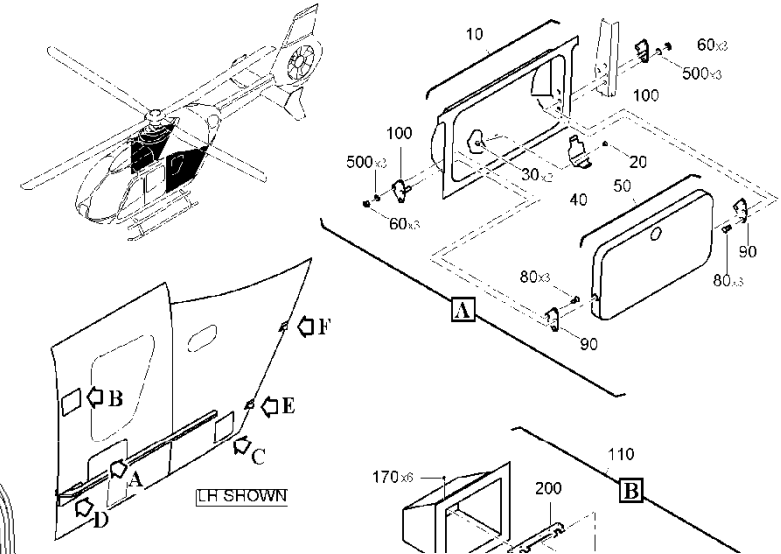



## Fuselage

### ● EC-135.

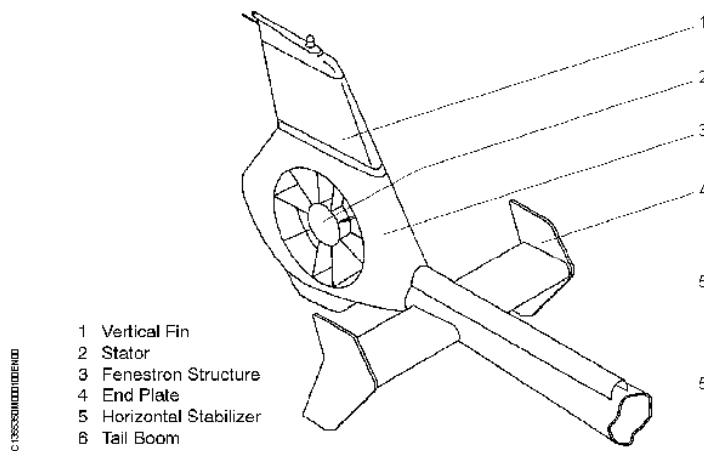

Components - Rear Structure

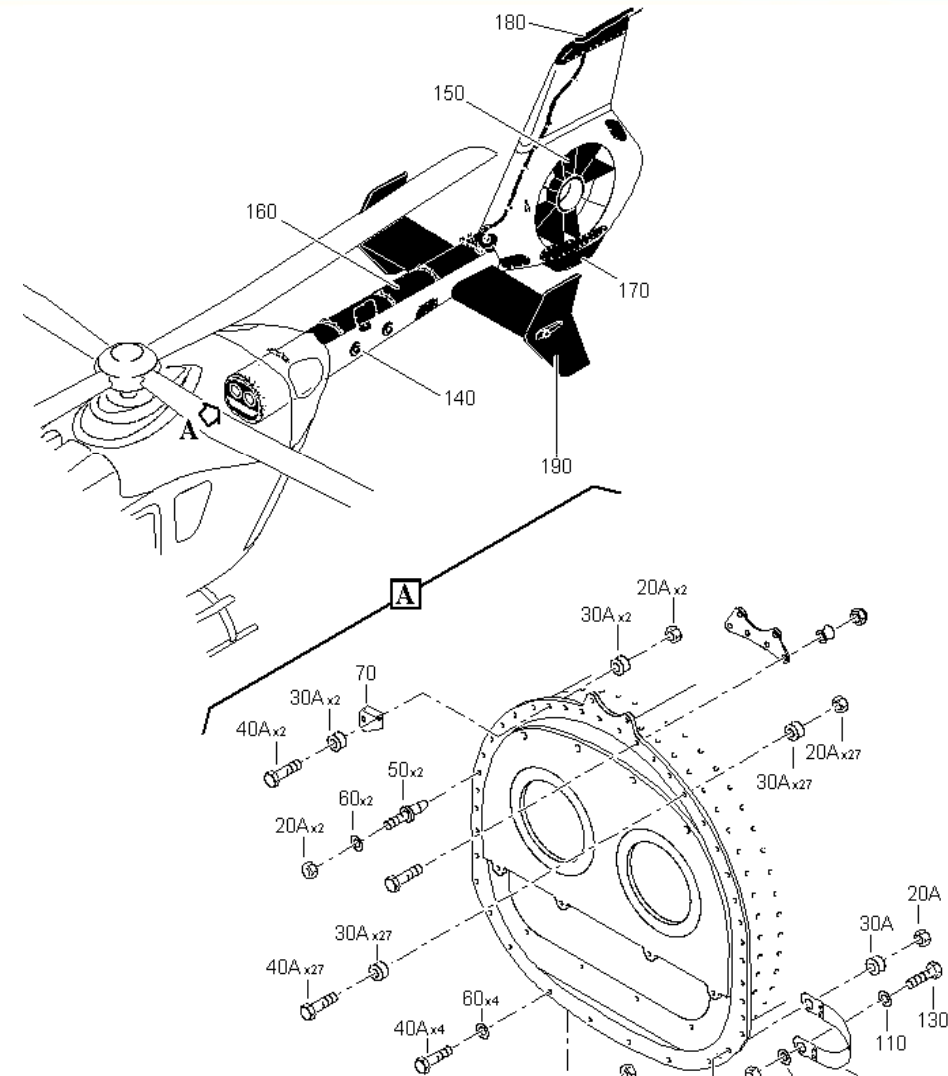



## Fuselage

- EC-135.







## Transmission frame





## Transmission frame

- There are different systems to minimise the vibrations produced by the main rotor.

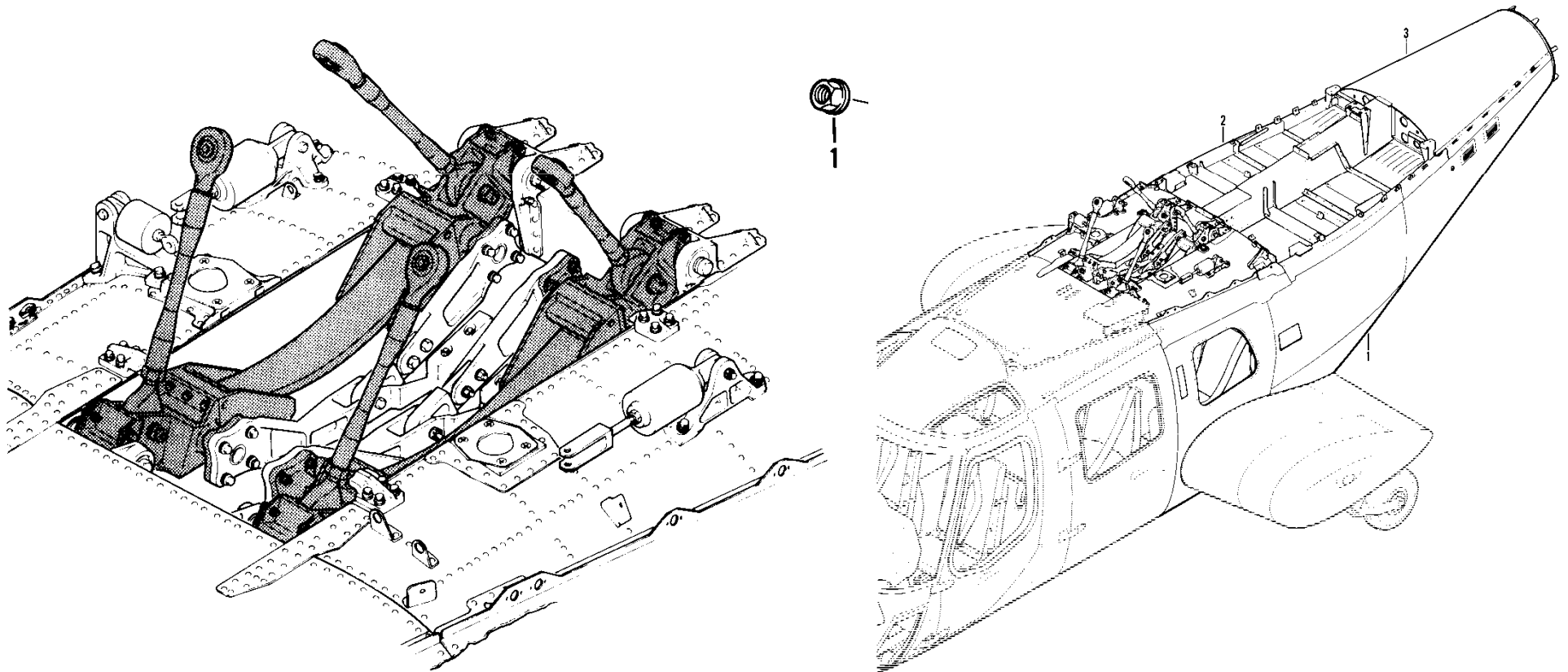



## Tail boom

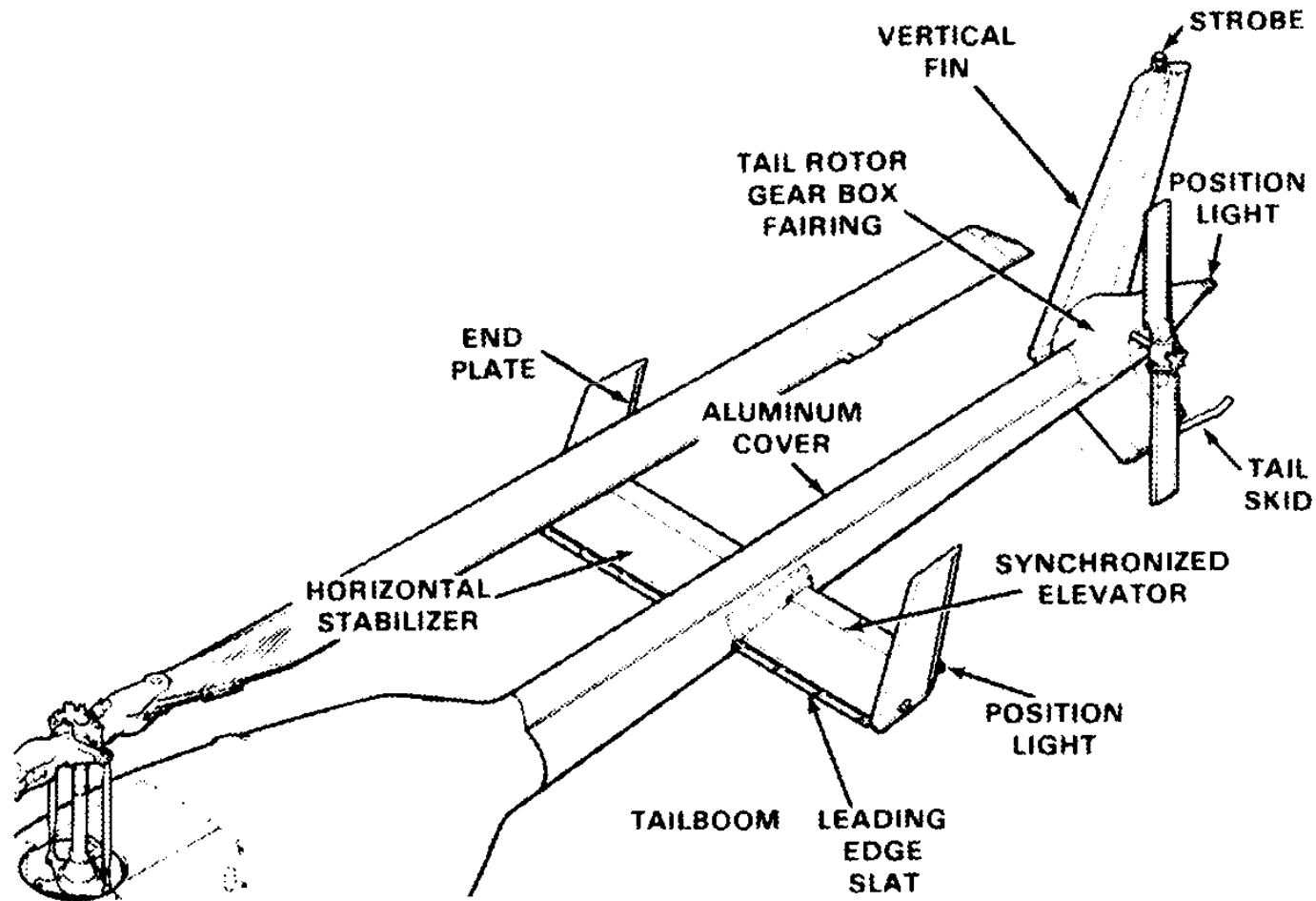





## Tail boom

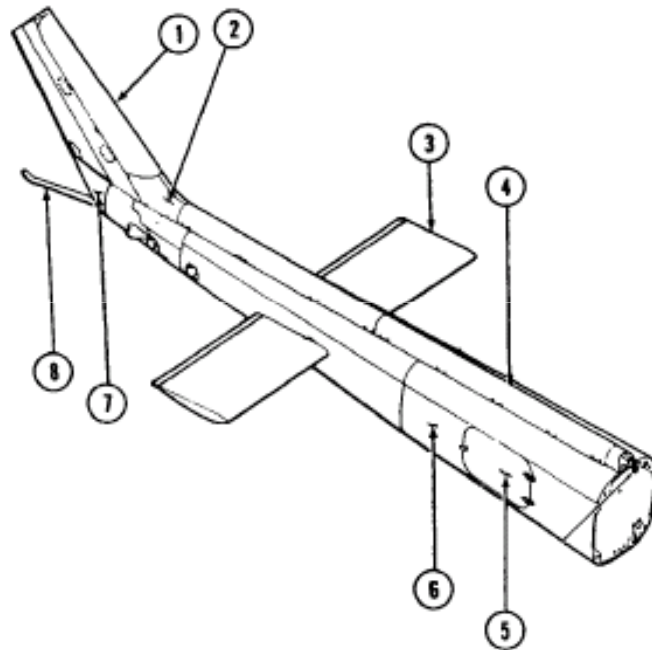

1. Vertical fin door
2. Intermediate gearbox cover
3. Aerodynamically actuated elevator
4. Tail rotor driveshaft cover
5. Baggage compartment door
6. Tailboom
7. Lower fin fairing
8. Tail skid

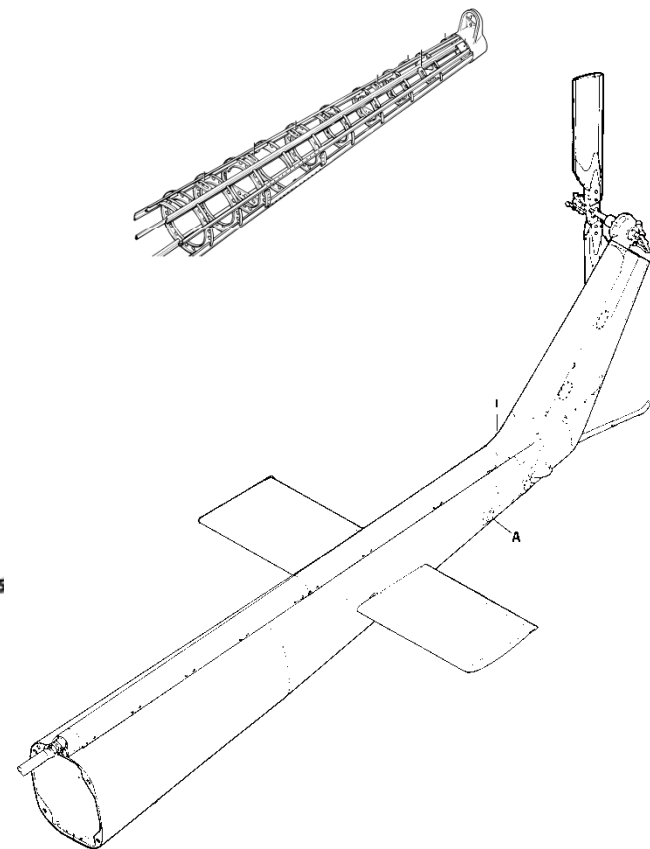



## Tail boom





## Tail boom

- EC 135 and Tiger.







## Tail boom

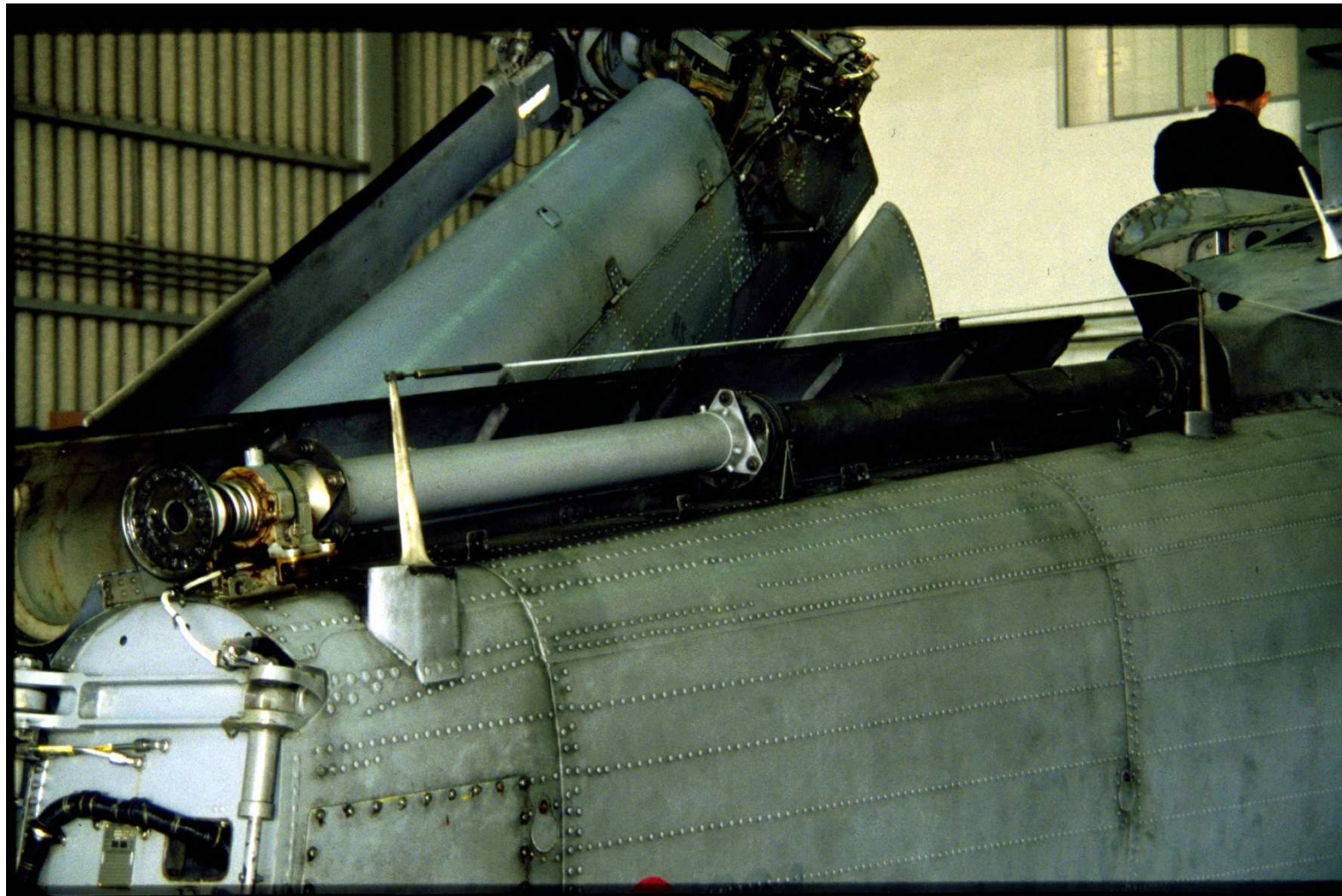



## Reference Lines

- Reference axes (3)
  - Corresponding to the Cartesian axes X, Y and Z.
- Aim:
  - To locate with precision any point on the helicopter
- Definitions:
  - **FS or STA**, fuselage stations, planes perpendicular to the X axis.
  - **WL (water lines)**, planes parallel to xy plane.
  - **BL (Butt lines)**, planes parallel to the “plane of symmetry” of the vehicle.



## Referece lines

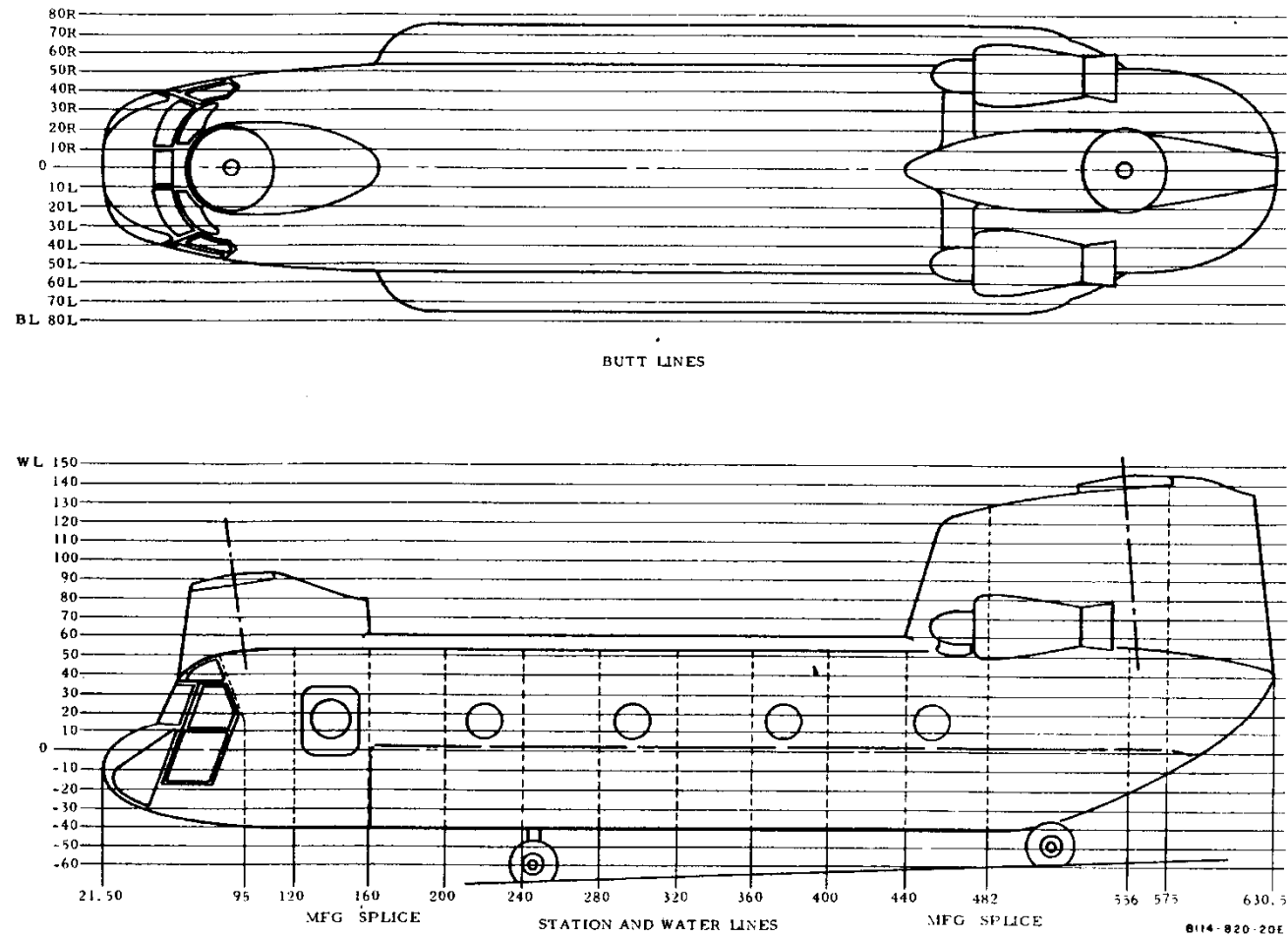

Figure 1-20. Fuselage Stations, Waterlines, and Buttlines (Sheet 2 of 2)





# REFERENCE LINES

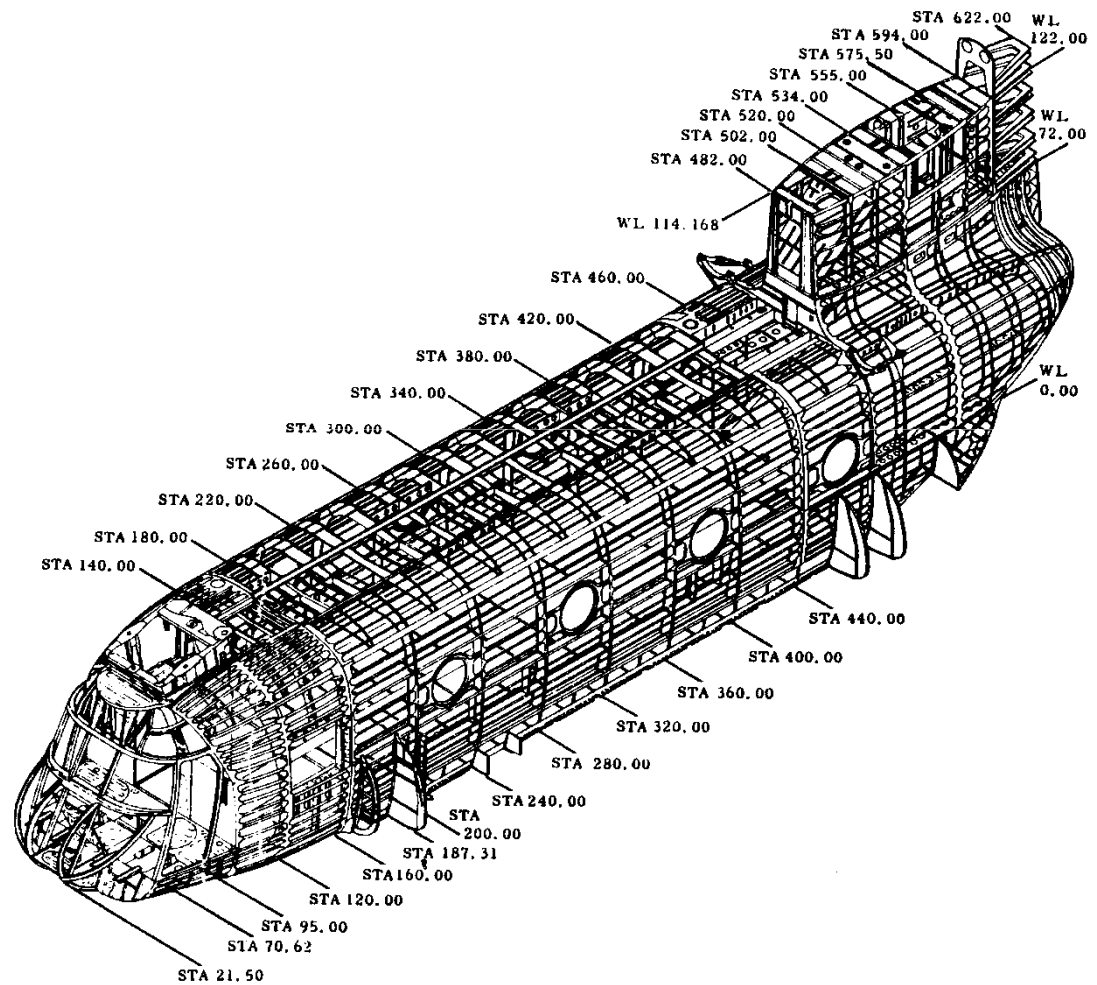

Figure 1-20. Fuselage Stations, Waterlines, and Buttlines (Sheet 1 of 2)



## Vertical Stabilizer

- Back sweep design.
- RC layout.
- Curvature of the airfoil
- Tail skid.
- Other configurations.



# VERTICAL STABILIZER

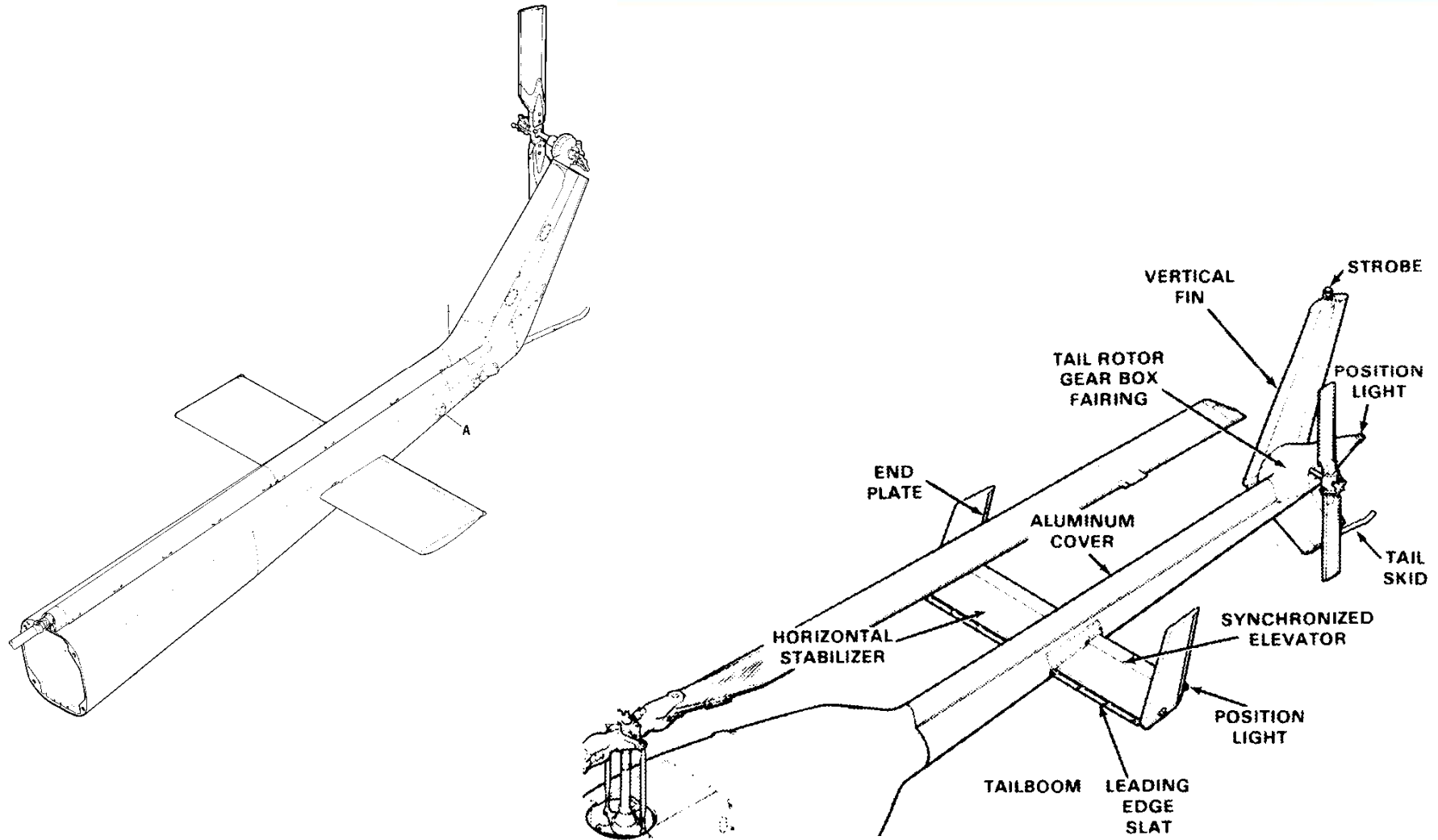





## Vertical stabilizer





## VERTICAL STABILIZER







## Horizontal Stabilizer

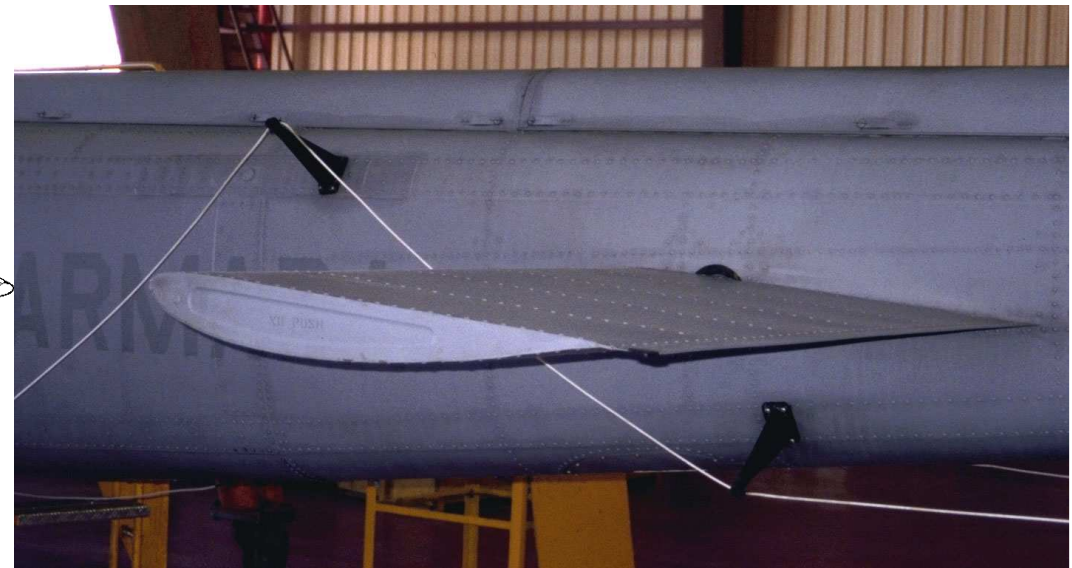
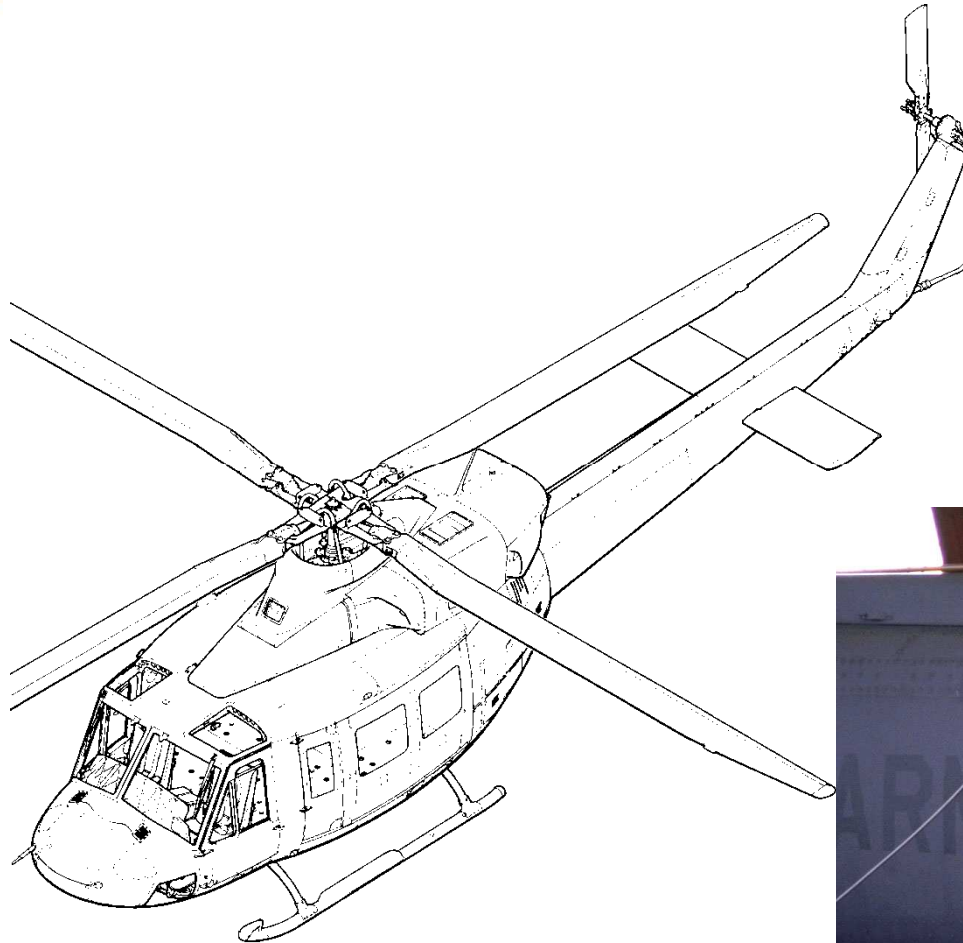







## Horizontal Stabilizer





## Horizontal Stabilizer







## Horizontal Stabilizer

COUGAR





# LANDING GEAR

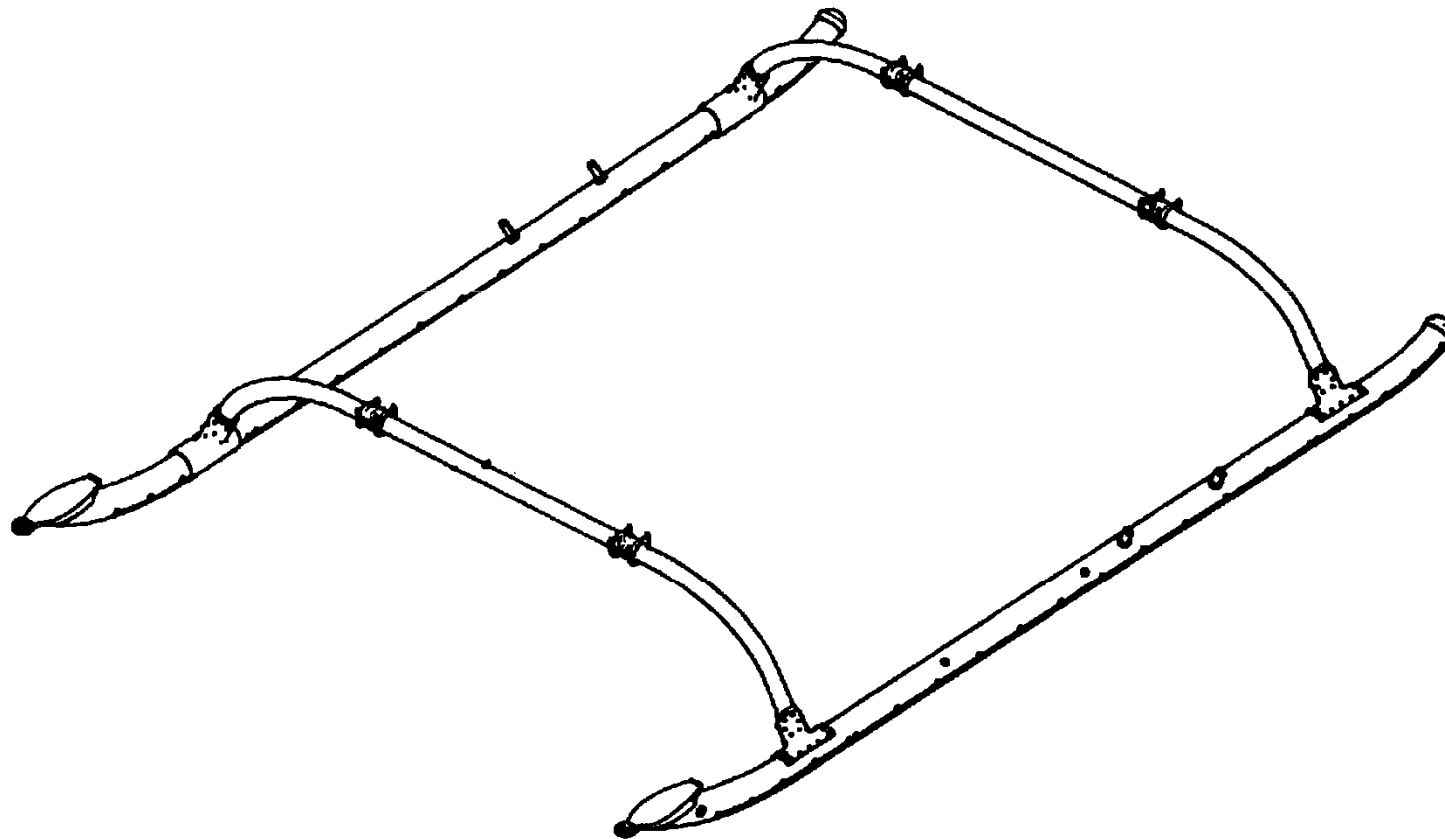



# LANDING GEAR







# LANDING GEAR

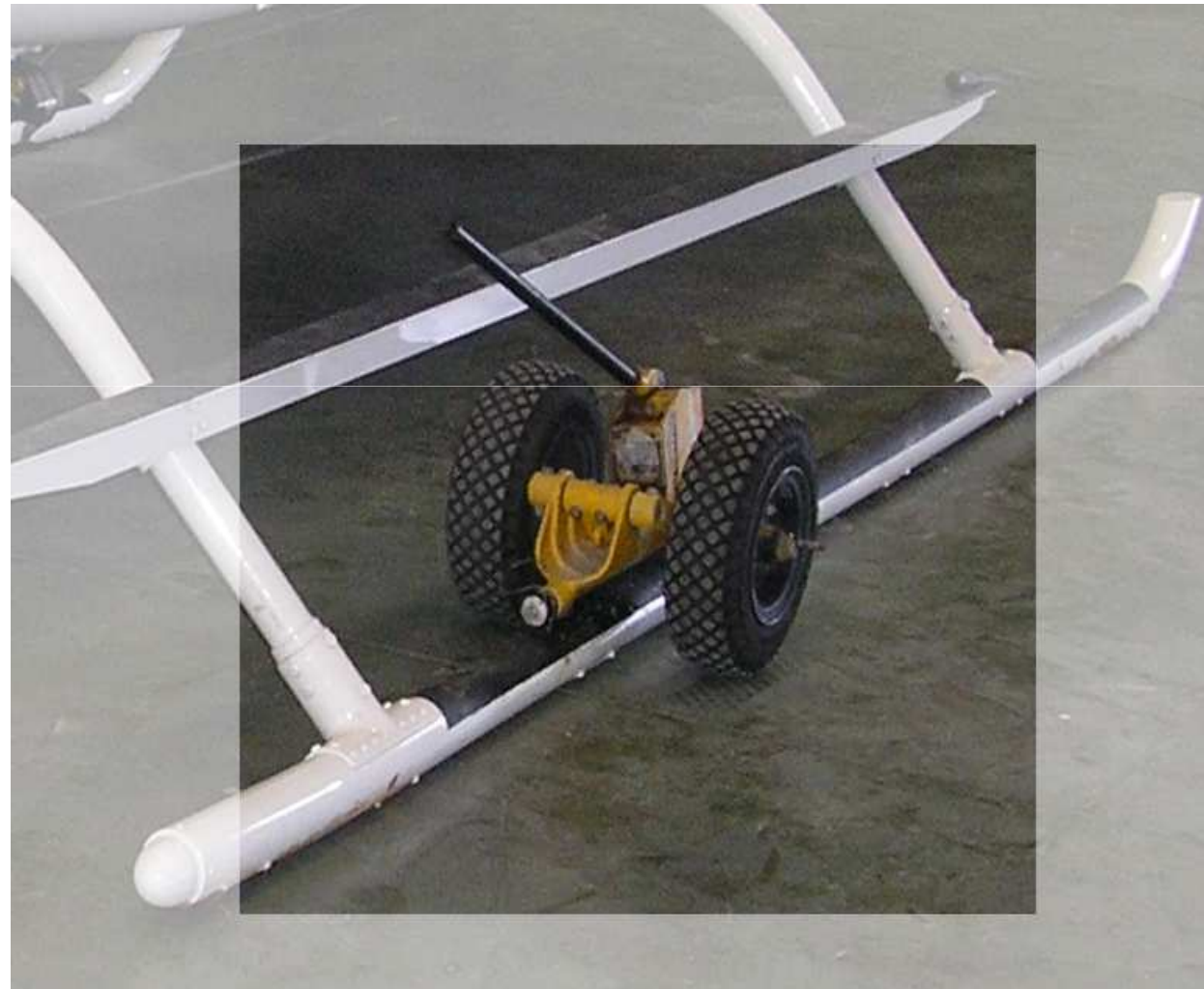



## LANDING GEAR

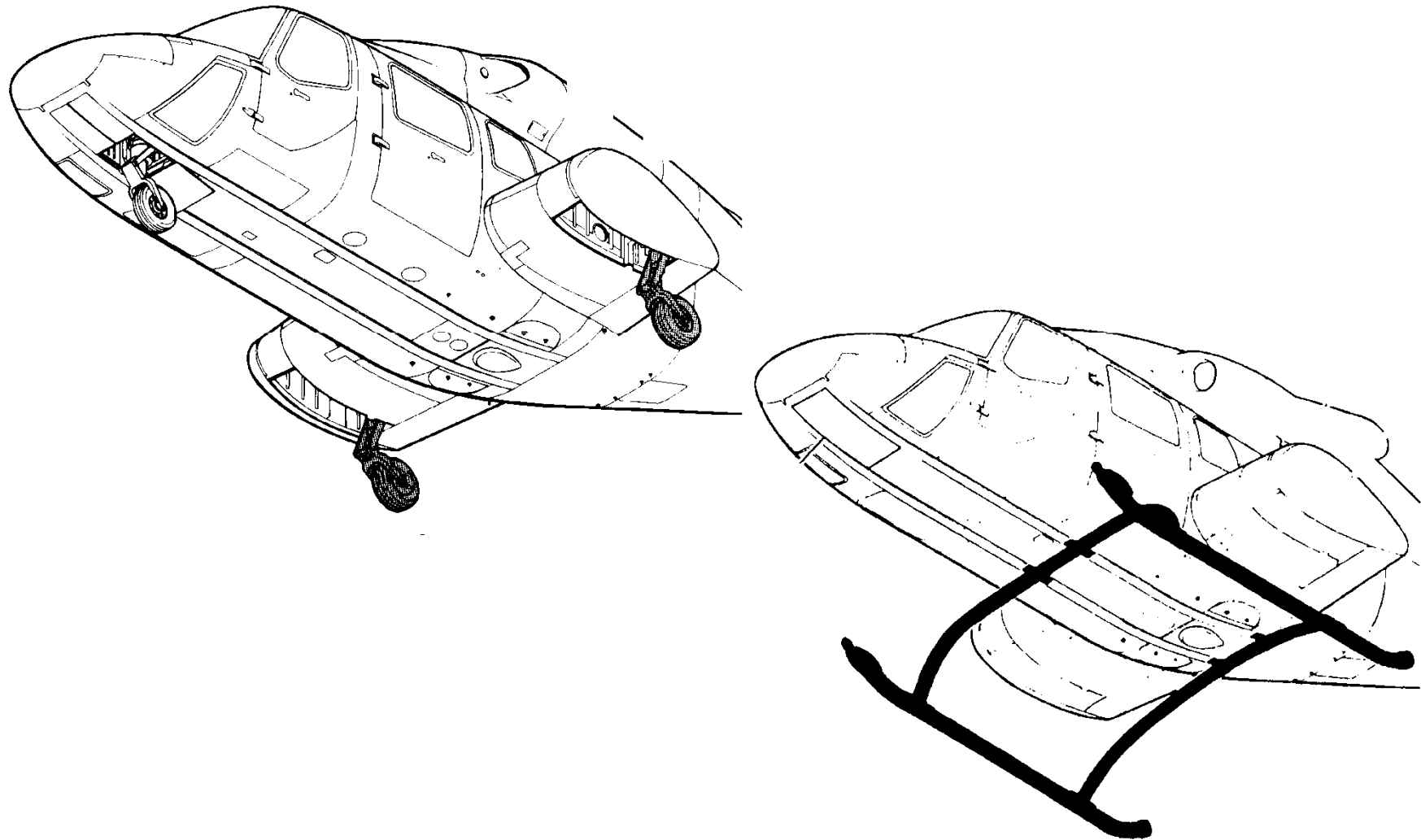



## LANDING GEAR







## LANDING GEAR

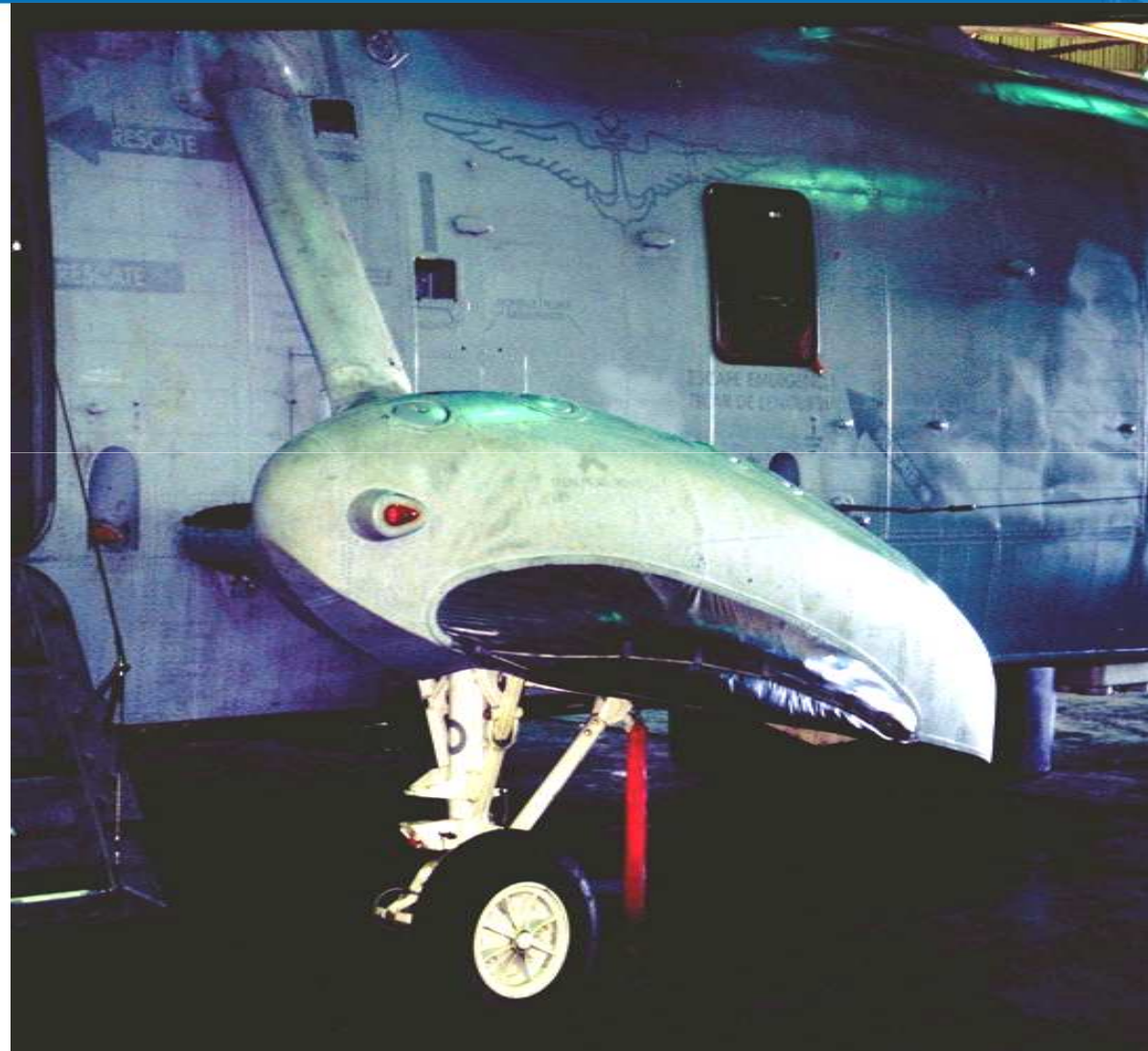



## LANDING GEAR

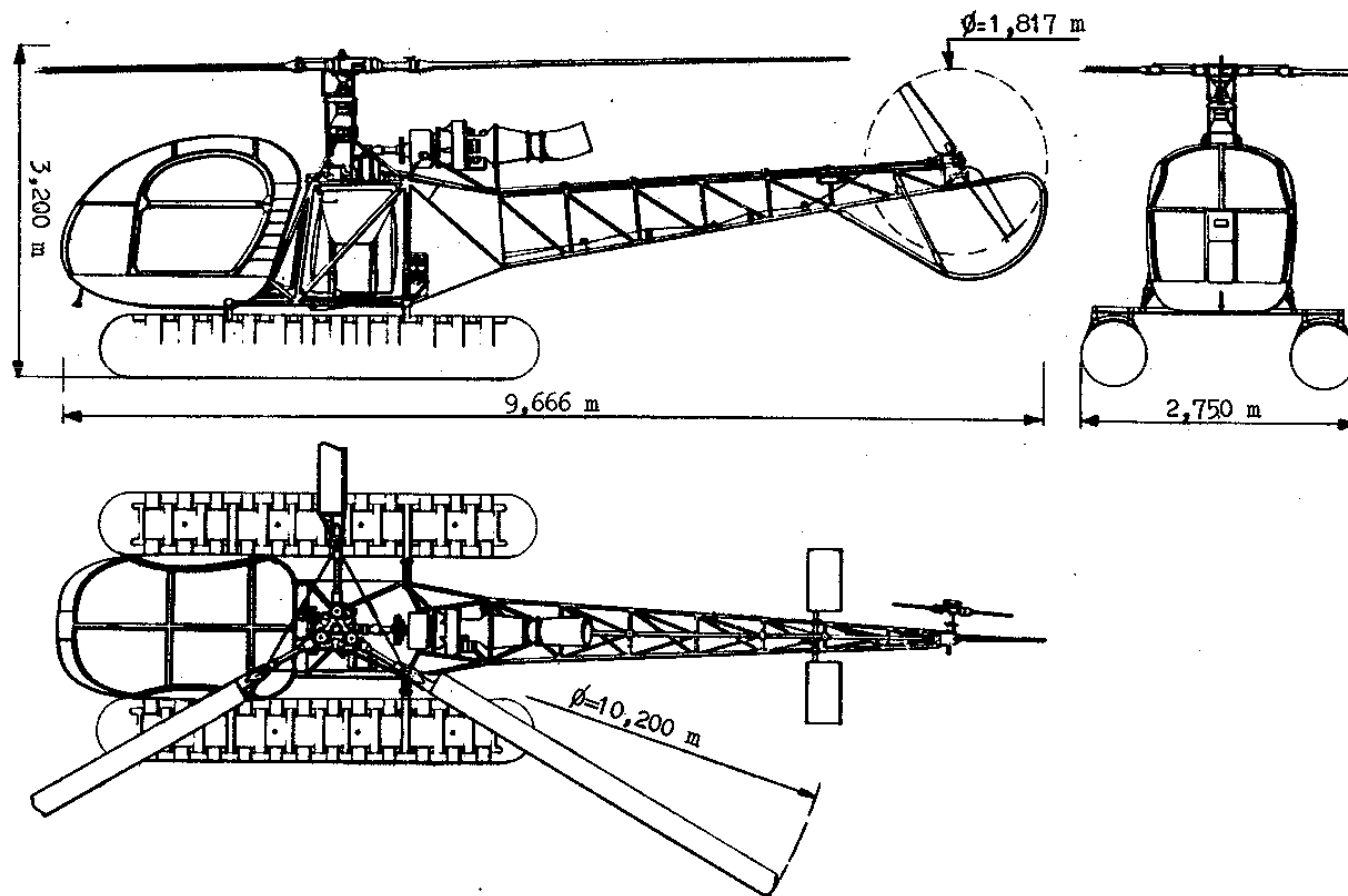



## Bibliography

- M.A. Barcala Montejano y A.A. Rodríguez Sevillano. *Helicópteros. Teoría y Descriptiva*. Sección de Publicaciones E.U.I.T.A. Fundación General U.P.M.
- Alastair K. Cooke, Eric W.H. Fitzpatrick. *Helicopter Test and Evaluation*. Blackwell Science.
- A.R.S. Bramwell, George Done, David Balmford. *Bramwell's Helicopter Dynamics*. Butterworth Heinemann, 2 edition 2001.
- J. Gordon Leishman. *Principles of Helicopter Aerodynamics*. Cambridge University Press, 2000.
- J. Seddon, Simon Newman. *Basic Helicopter Aerodynamics*. Blackwell Science, second edition 2002.
- John Watkinson. *The Art of the Helicopter*. Elsevier Butterwoth Heinemann, 2004.