



Universidad Politécnica de Madrid

Uso del IoT para construir tú mismo un hogar digital

Diseño hardware de actuador de enchufe

Iván Pau

Configuración inicial



POLITÉCNICA



Universidad Politécnica de Madrid

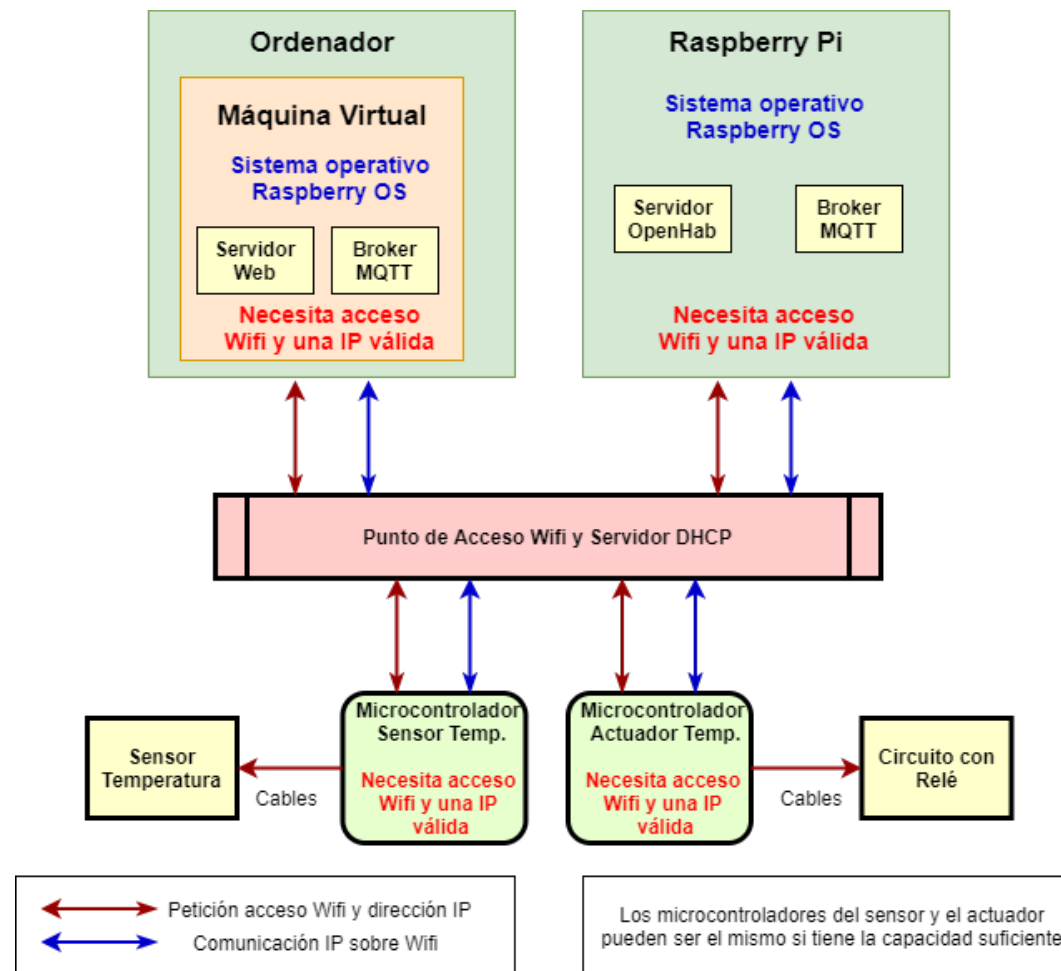

¿Qué vamos a hacer?

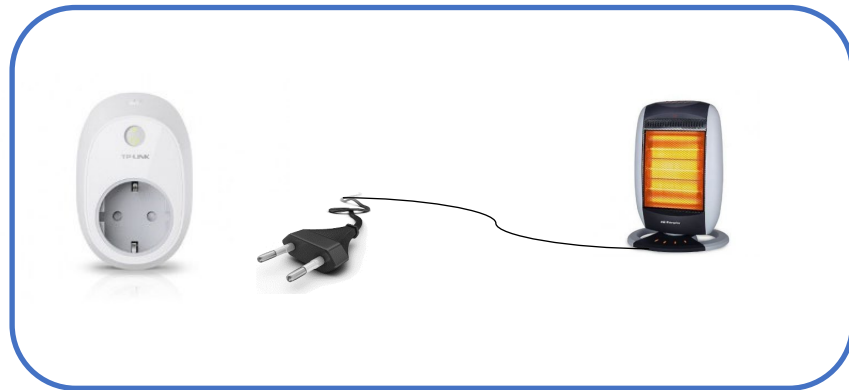

ESP8266 (Lolin D1 mini)

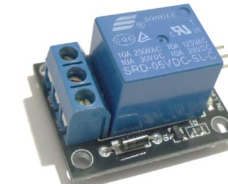

Relé



Fuente alimentación 5v



Cables

Lolin D1 mini



Pin

wemos.cc/en/latest/d1/d1_mini.html

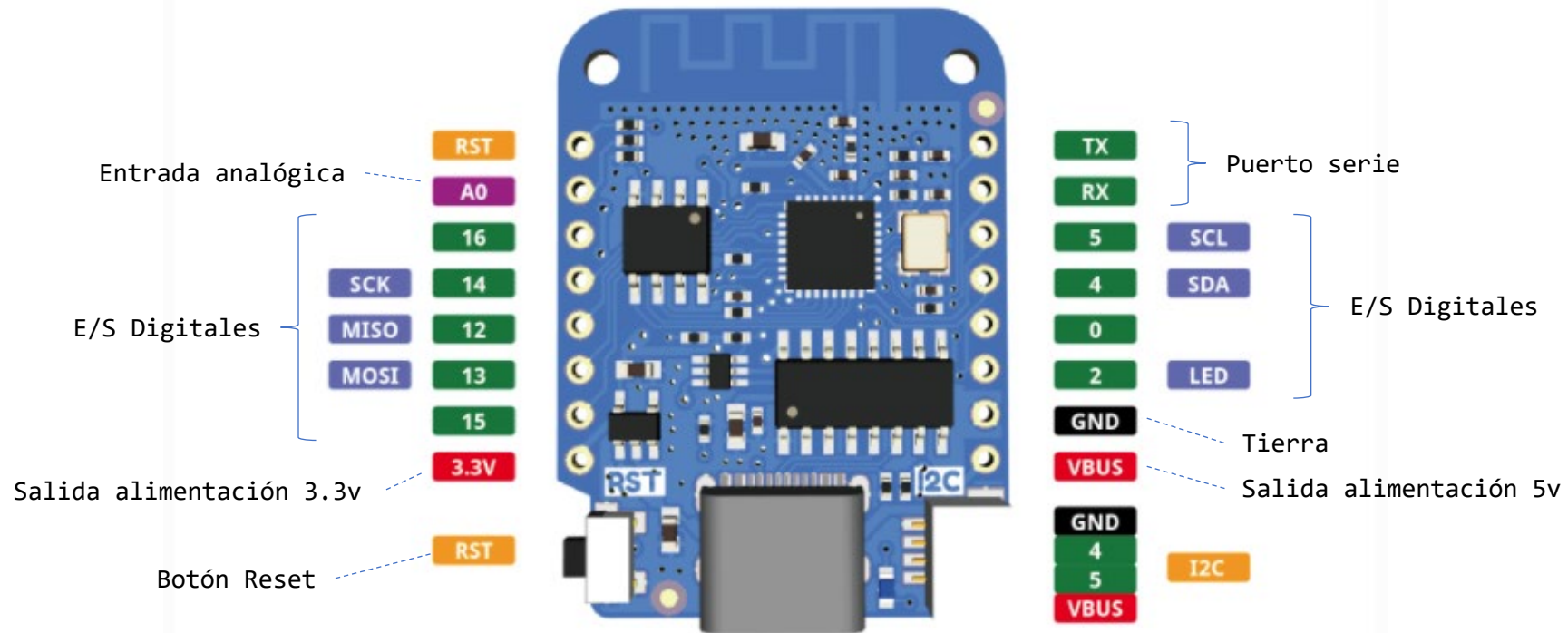

Note

All of the IO pins run at 3.3V.

Recuerdo: uso de pines

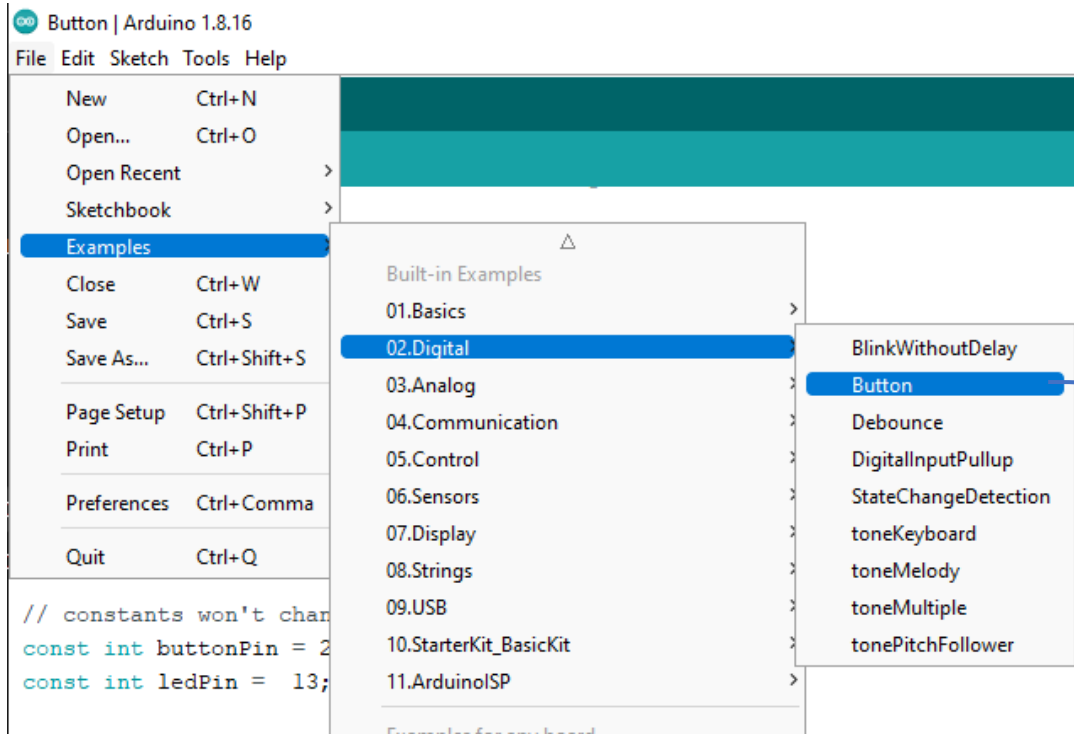

```
// constants won't change. They're used here to set pin numbers:  
const int buttonPin = 2; // the number of the pushbutton pin  
const int ledPin = 13; // the number of the LED pin
```

```
// variables will change:  
int buttonState = 0; // variable for reading the pushbutton status
```

```
void setup() {  
  // initialize the LED pin as an output:  
  pinMode(ledPin, OUTPUT);  
  // initialize the pushbutton pin as an input:  
  pinMode(buttonPin, INPUT);  
}
```

```
void loop() {  
  // read the state of the pushbutton value:  
  buttonState = digitalRead(buttonPin);
```

```
  // check if the pushbutton is pressed. If it is, the buttonState is HIGH:  
  if (buttonState == HIGH) {  
    // turn LED on:  
    digitalWrite(ledPin, HIGH);  
  } else {  
    // turn LED off:  
    digitalWrite(ledPin, LOW);  
  }  
}
```

Lolin D1 mini – Números PIN

```
26 #ifndef Pins_Arduino_h
27 #define Pins_Arduino_h
28
29 #define PIN_WIRE_SDA (4)
30 #define PIN_WIRE_SCL (5)
31
32 static const uint8_t SDA = PIN_WIRE_SDA;
33 static const uint8_t SCL = PIN_WIRE_SCL;
34
35 #define LED_BUILTIN 2
36
37 static const uint8_t D0 = 16;
38 static const uint8_t D1 = 5;
39 static const uint8_t D2 = 4;
40 static const uint8_t D3 = 0;
41 static const uint8_t D4 = 2;
42 static const uint8_t D5 = 14;
43 static const uint8_t D6 = 12;
44 static const uint8_t D7 = 13;
45 static const uint8_t D8 = 15;
46 static const uint8_t RX = 3;
47 static const uint8_t TX = 1;
```

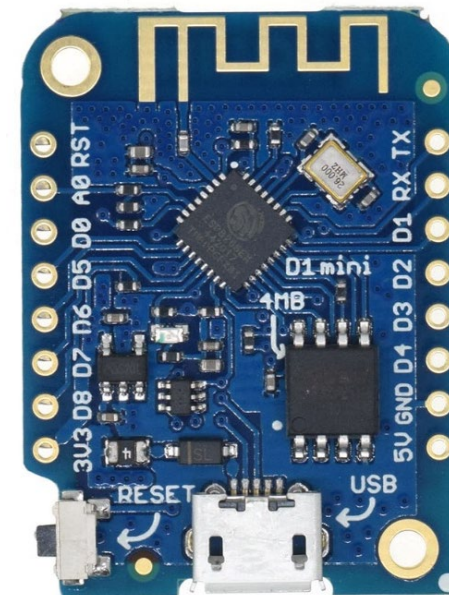
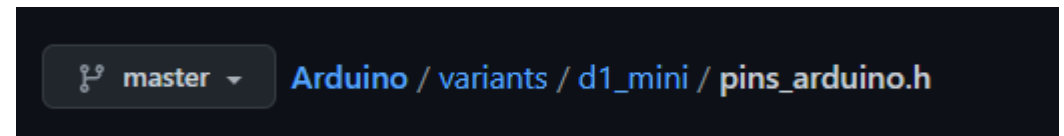
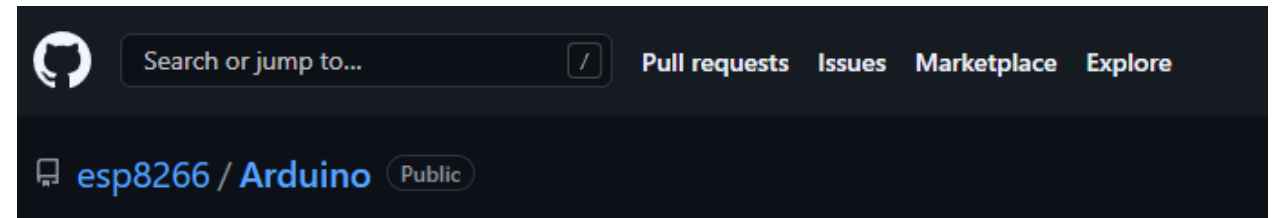

Relés

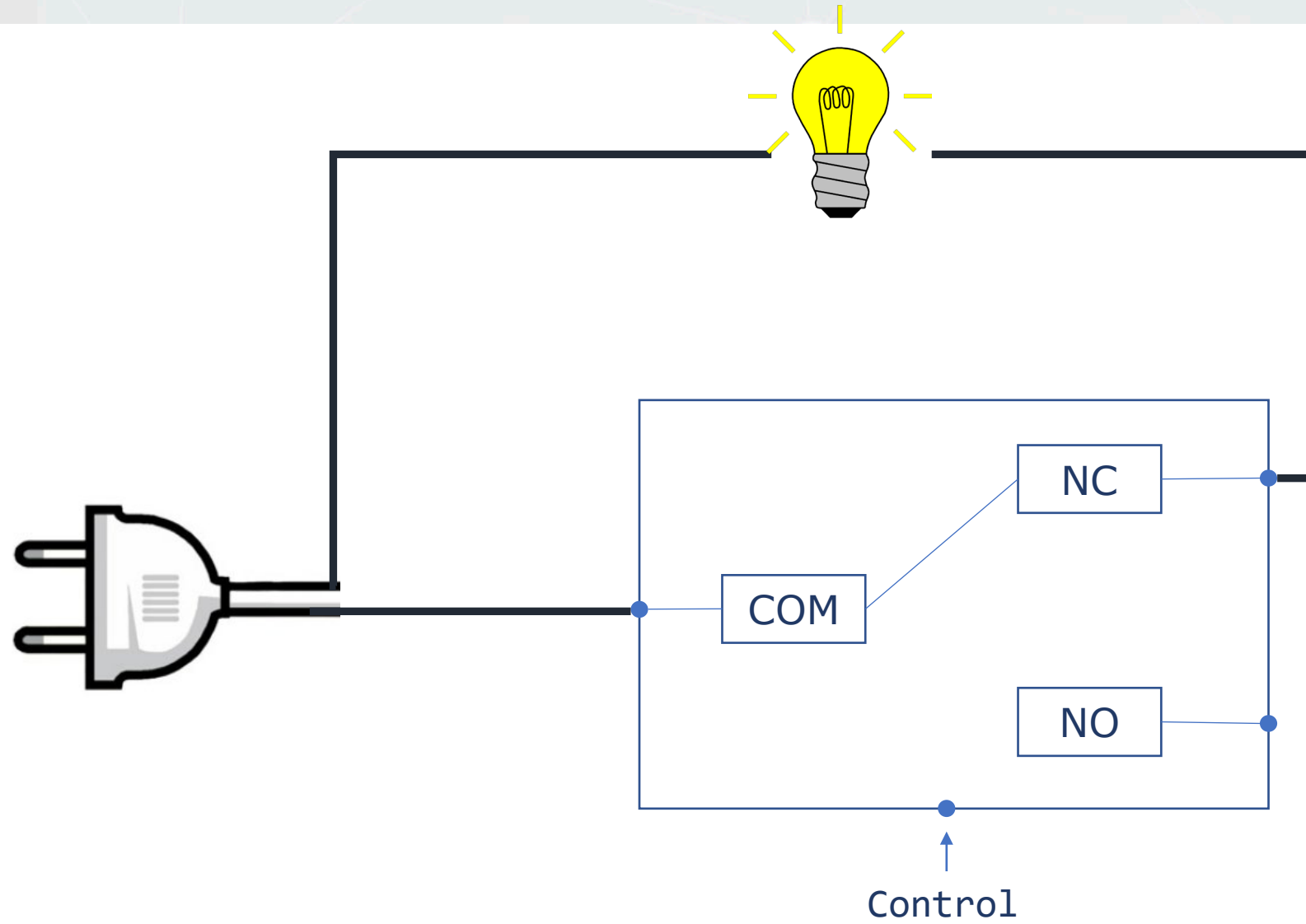

Principios de diseño

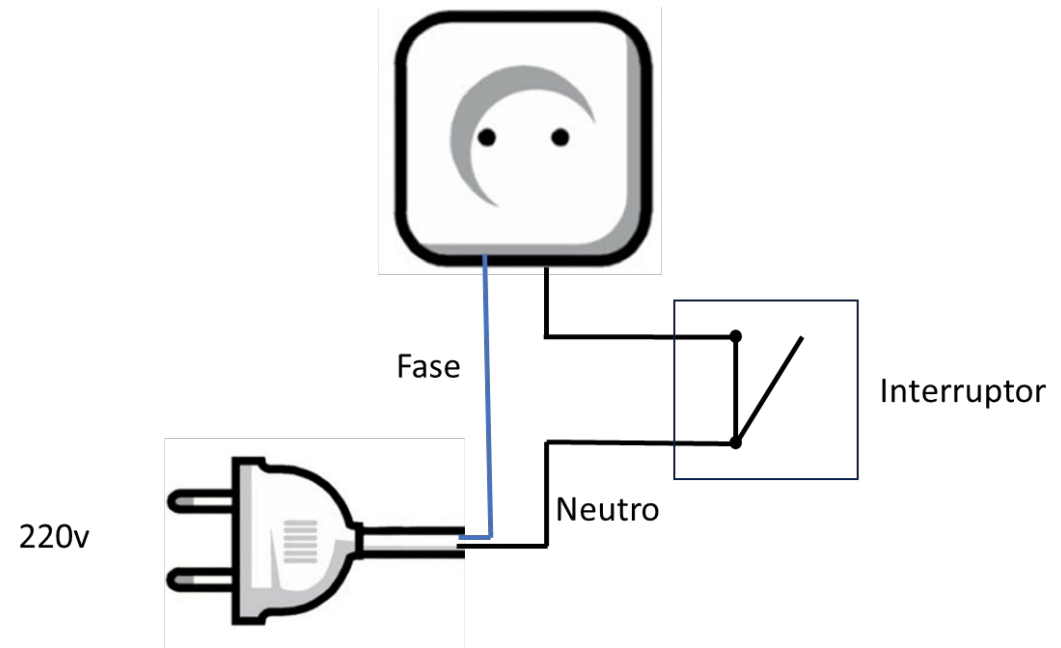
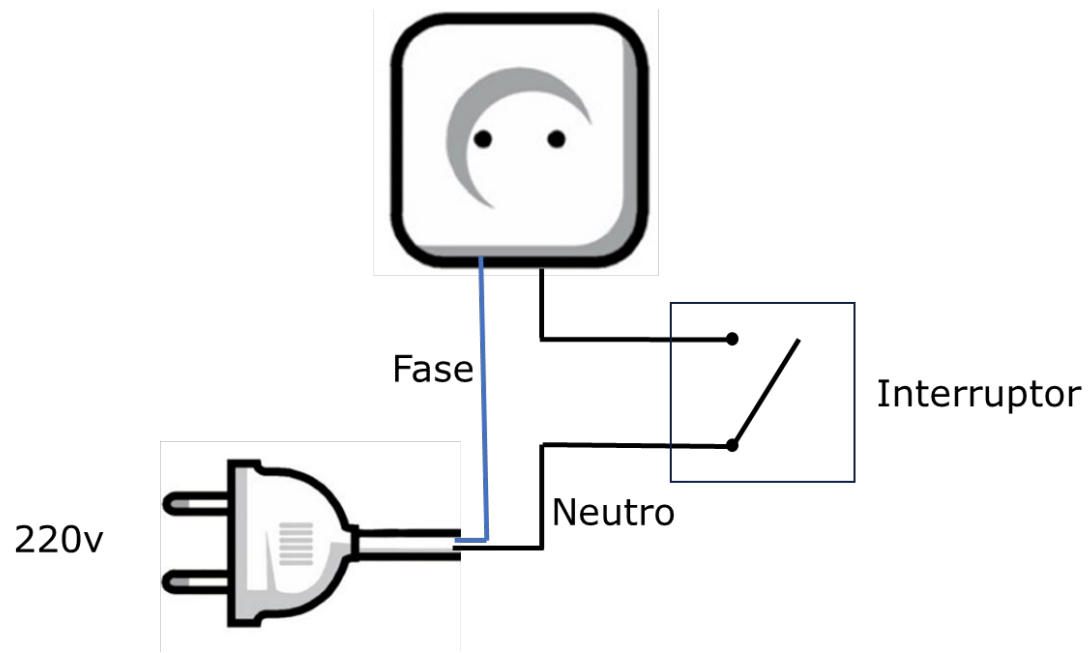

Principios de diseño

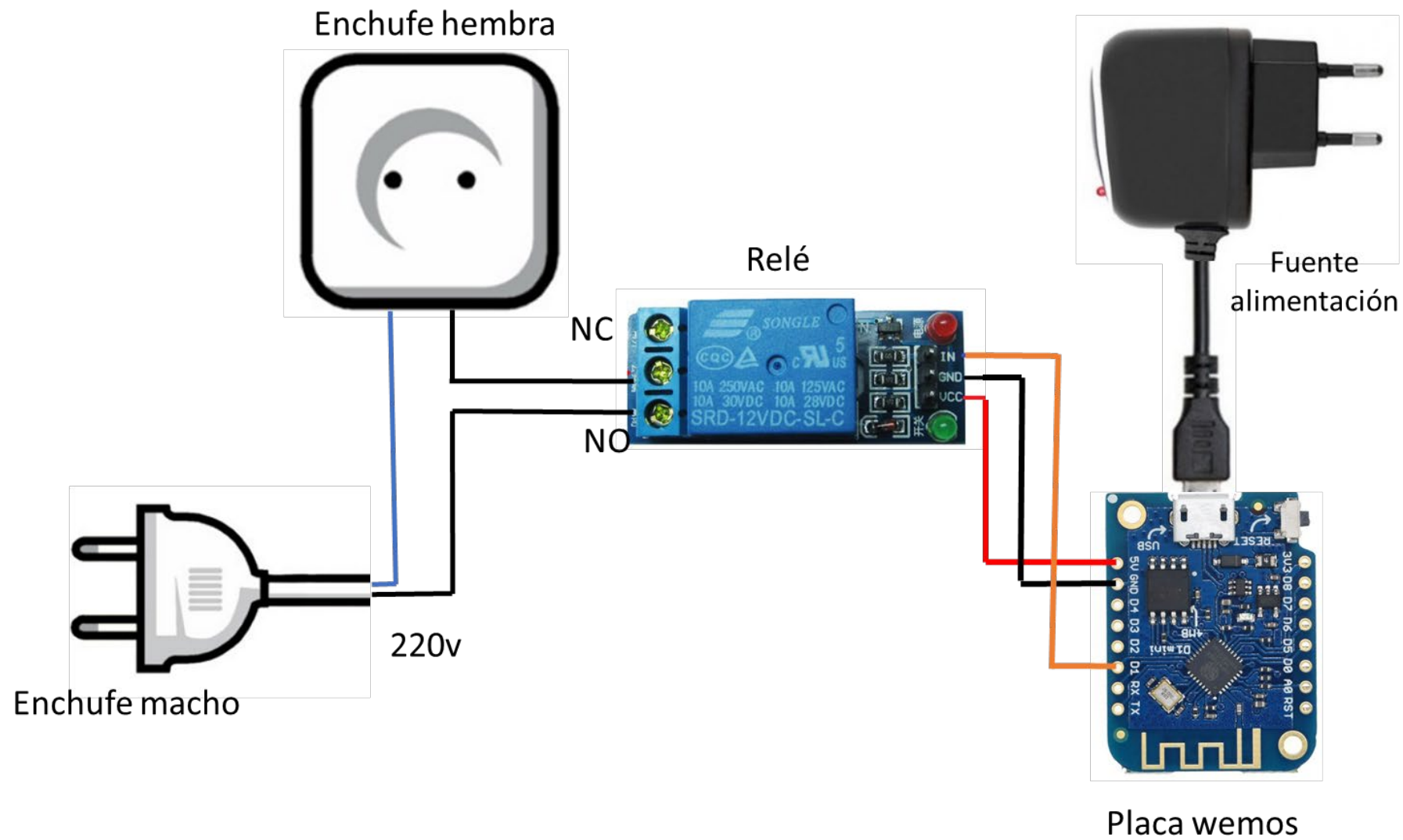

Principios de diseño

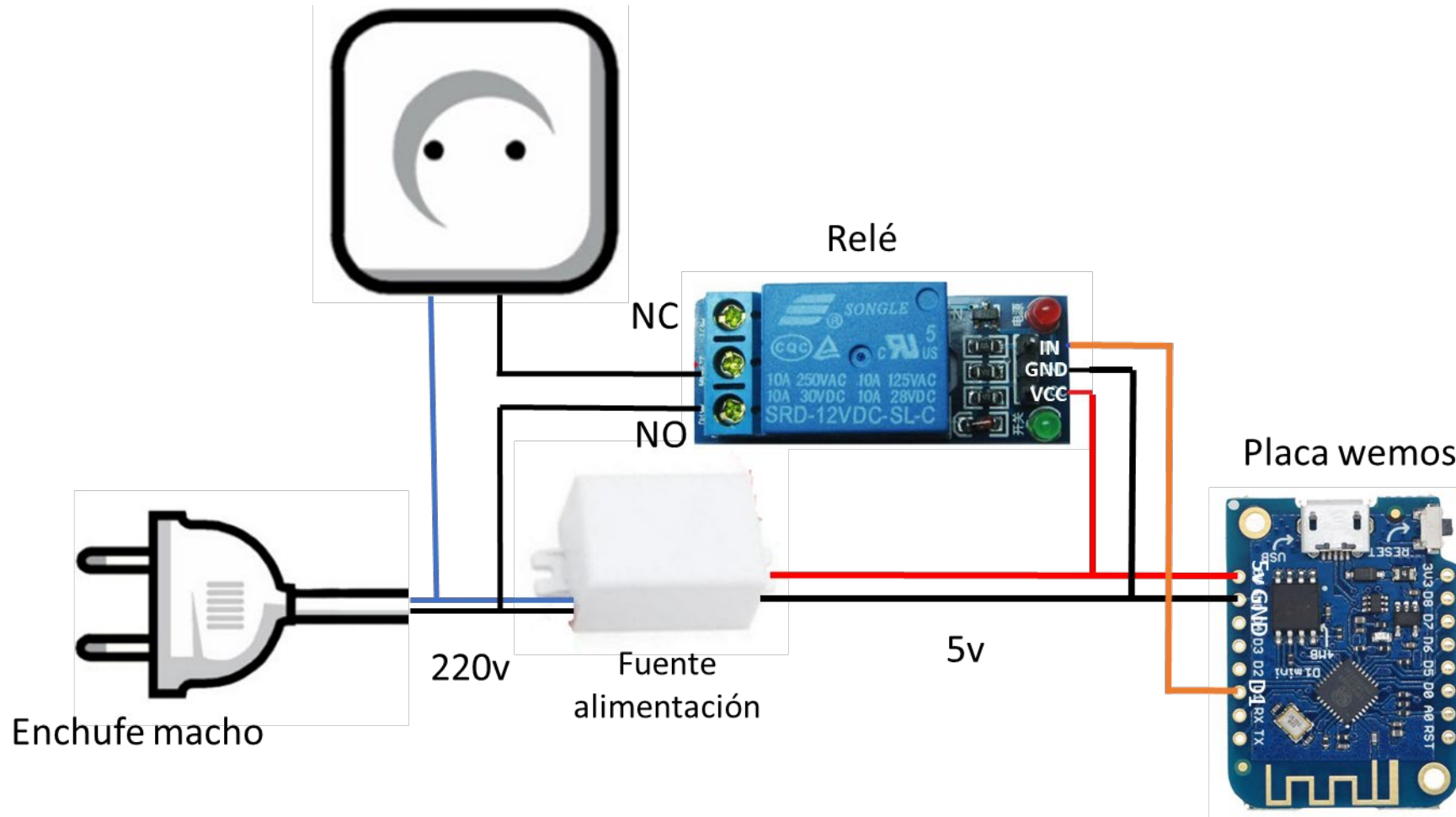



WeMos Relay Shield



Docs » D1 Mini Shields » Relay Shield

[Edit on GitHub](#)

Relay Shield

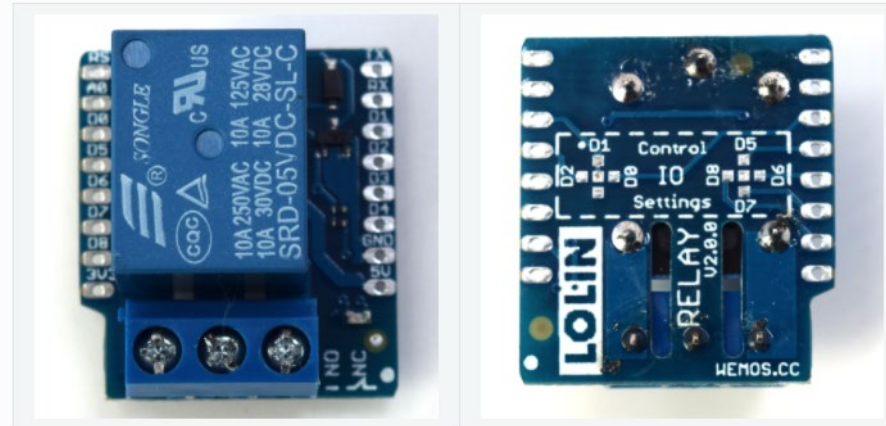

Simple relay shield. [Buy it]

Features

- NO: 5A(250VAC/30VDC), 10A(125VAC), MAX:1250VA/150W
- NC: 3A(250VAC/30VDC), MAX:750VA/90W
- 7 configurable IO, default: D1(GPIO5)

Pins

D1 mini	GPIO	Shield
D1	5	RELAY

¿Cómo lo implementamos?



POLITÉCNICA



Universidad Politécnica de Madrid

Pero, ¿donde monto todo esto?



¿Cómo lo implementamos?

Pero, ¿donde monto todo esto?



Montajes más seguros



POLITÉCNICA



Universidad Politécnica de Madrid

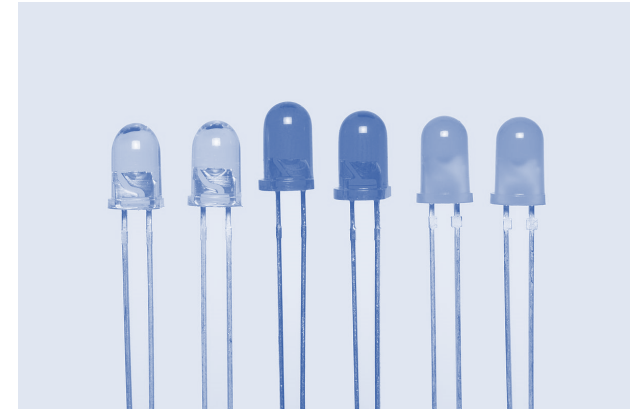
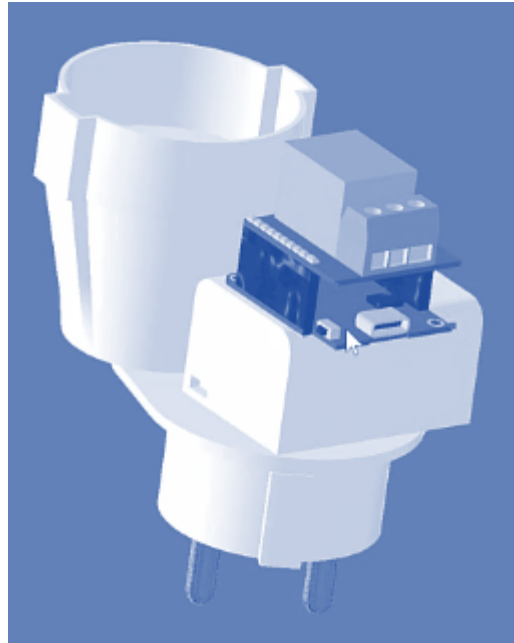

Montaje extensor comercial

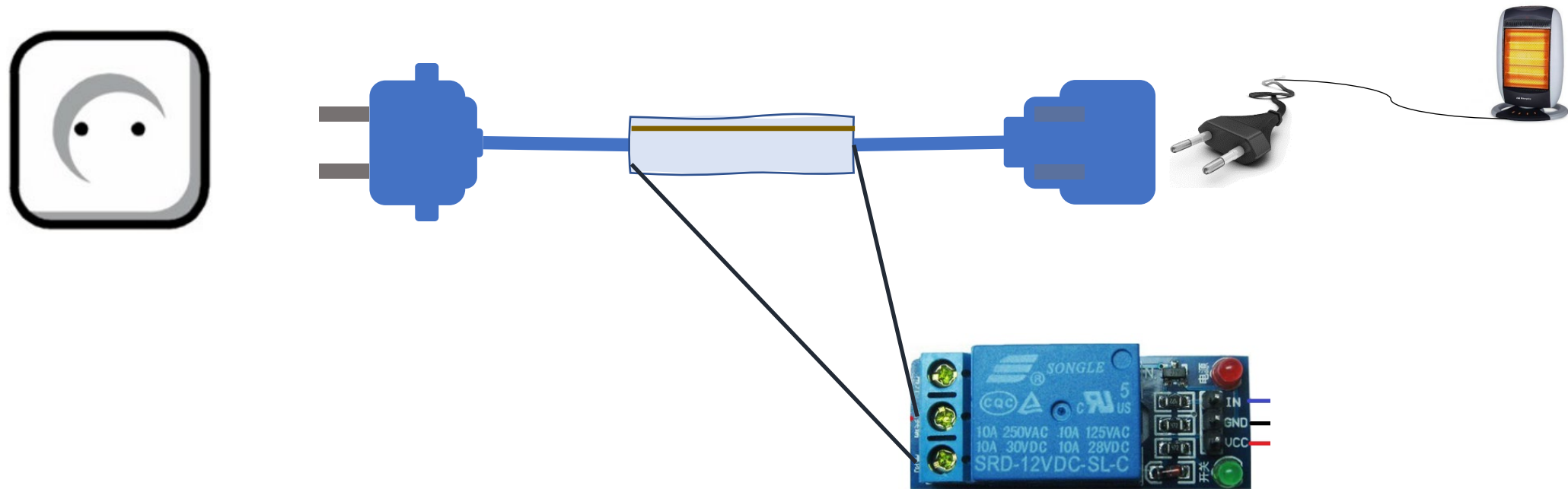

Montaje extensor comercial

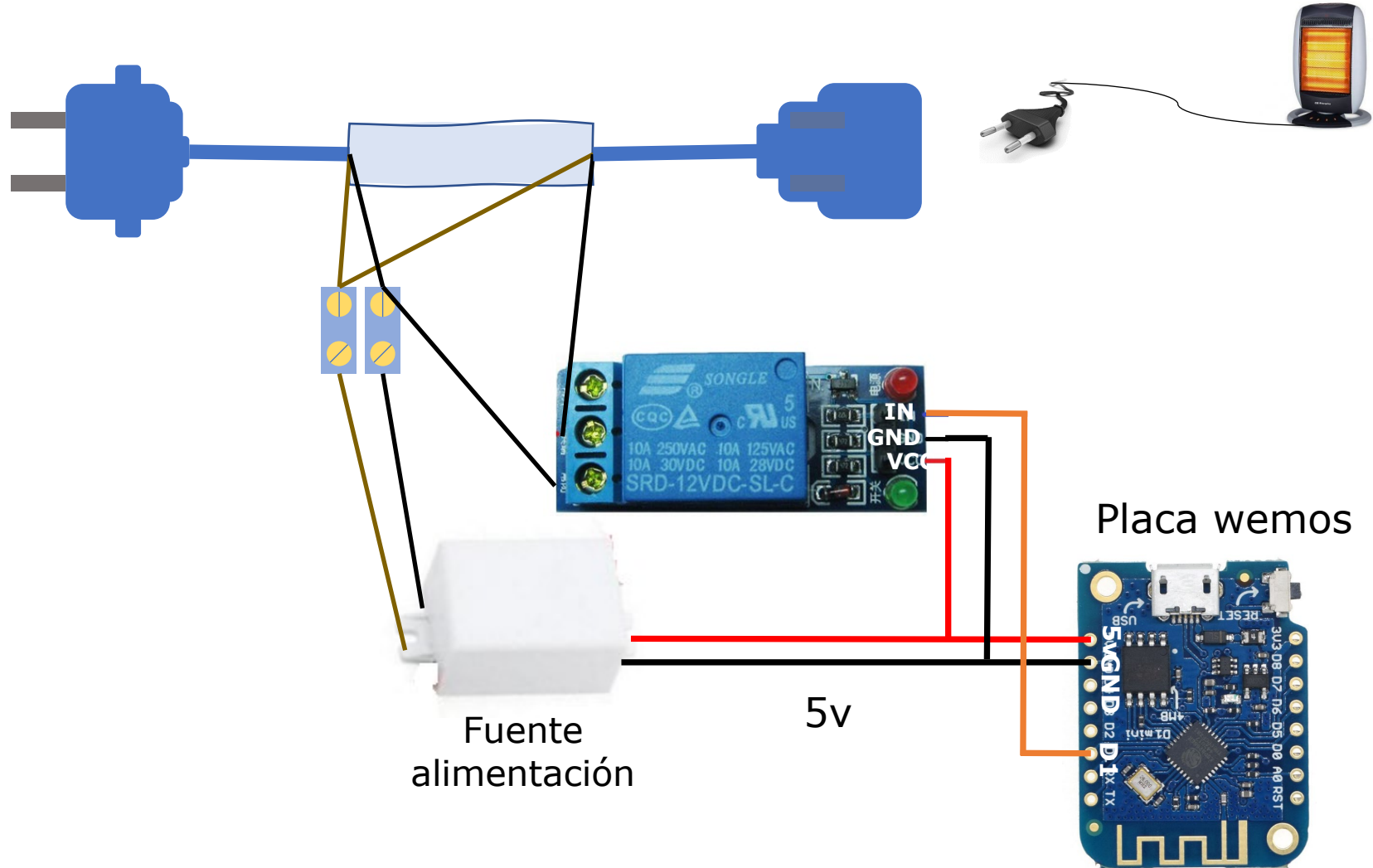

Montaje extensor manual

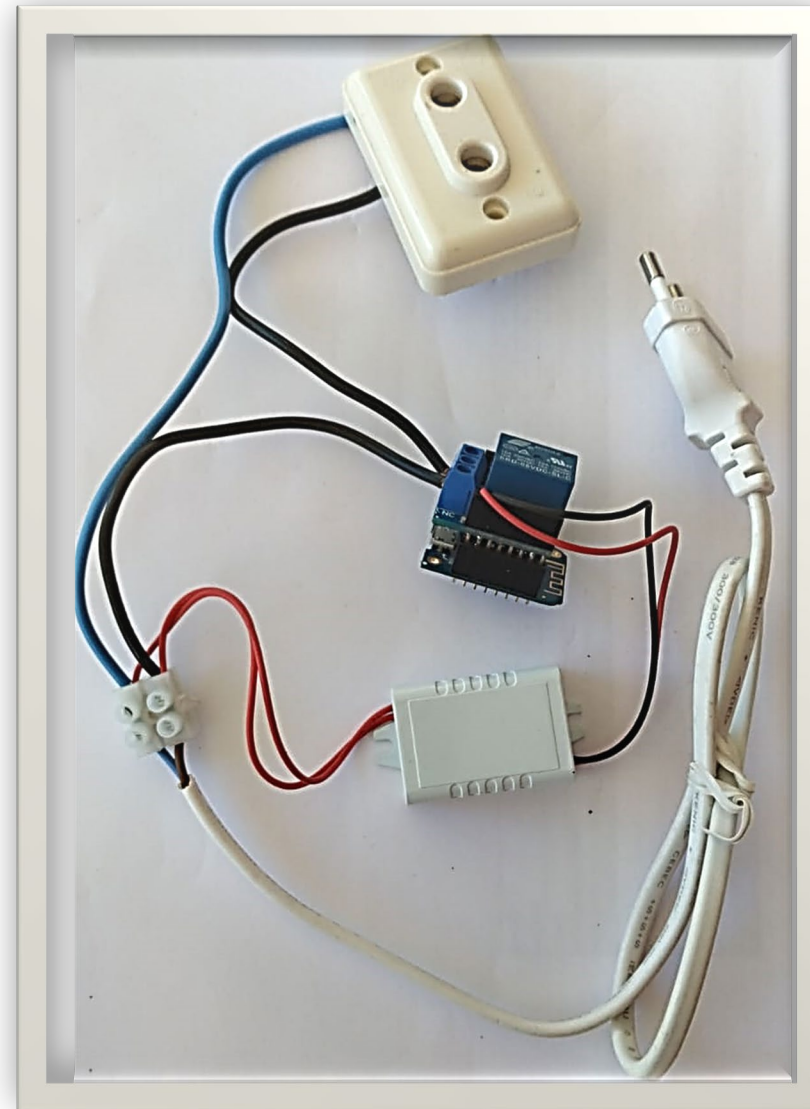
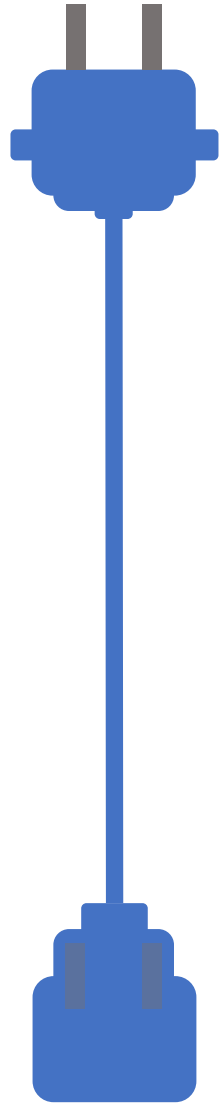

Usar caja macho-hembra

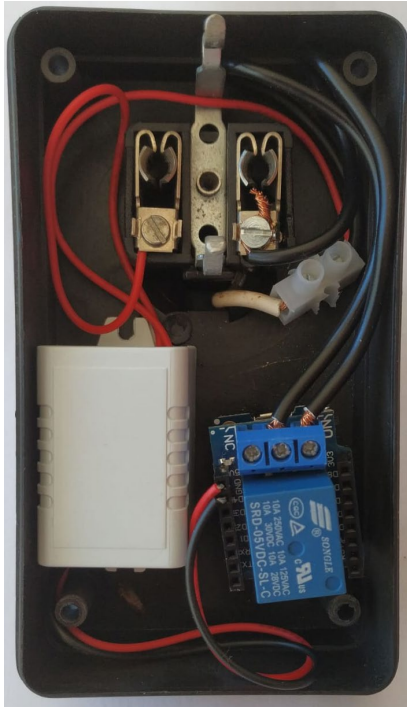

Uso de Leds



POLITÉCNICA



Universidad Politécnica de Madrid

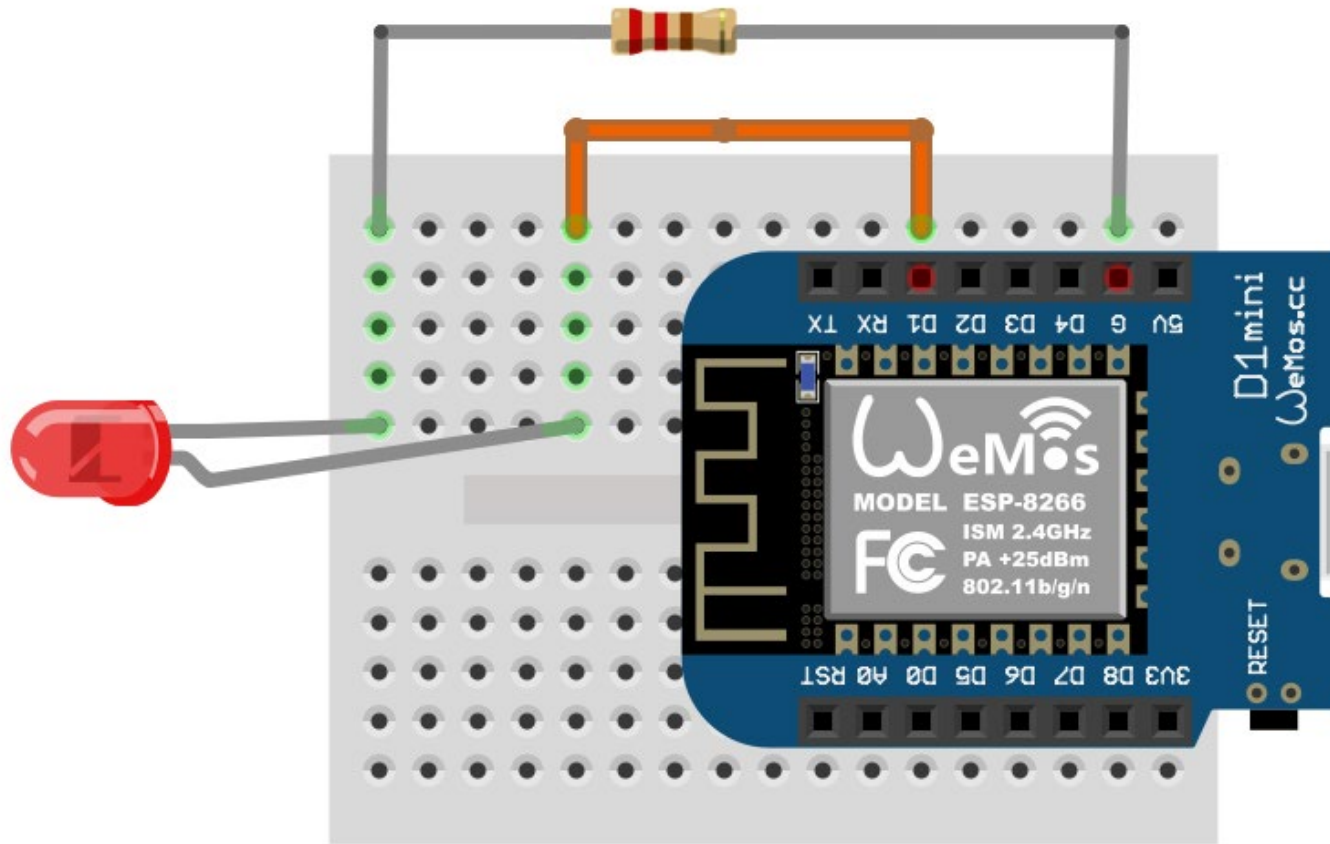

Retos: diseña tus actuadores

¿Cómo harías un ACTUADOR DE INTERRUPTOR?

Es similar al del enchufe PERO también debe integrarse a nivel HW un pulsador

El pulsador debe ser monitorizado por uno de los pines digitales del microcontrolador para saber cuando ha sido pulsado (el pulsador no corta la fase, eso lo hace el relé)

Haz una simulación hacienda que el relé sea un LED:
LED encendido = relé activo
LED apagado = relé no activo

Esquema de conexión

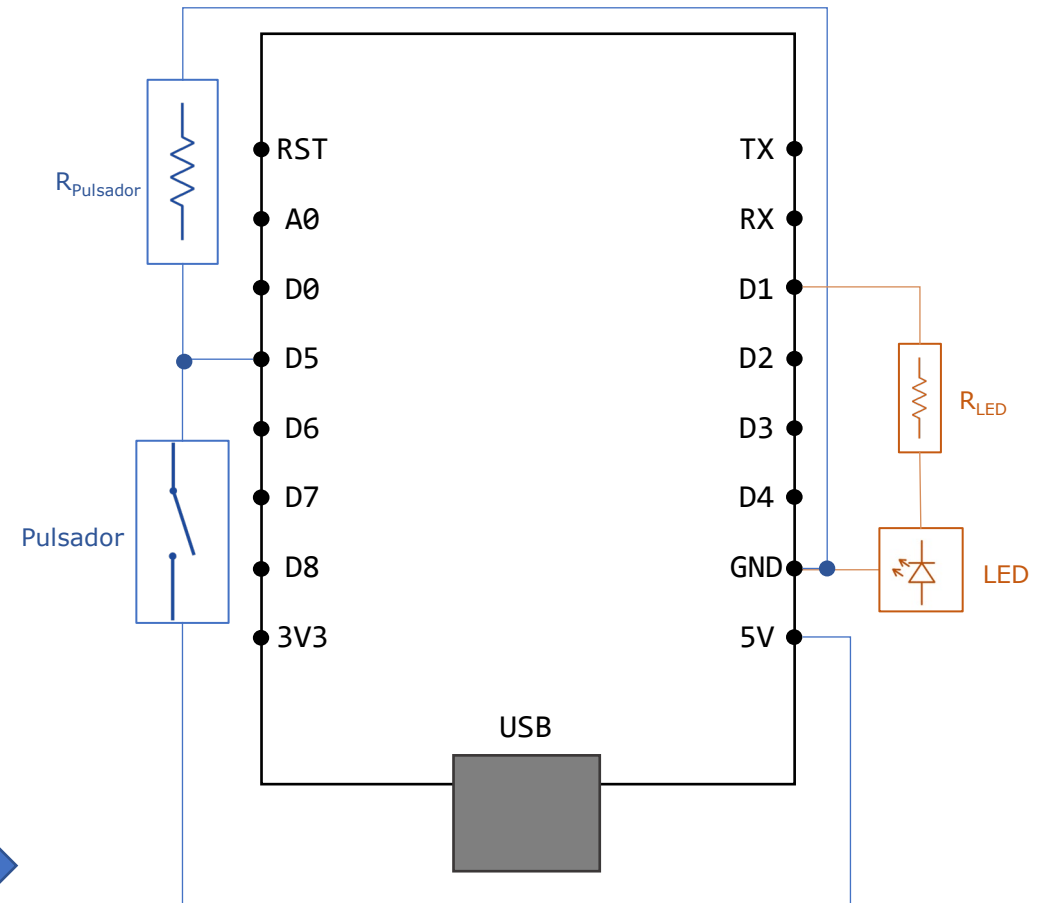

Retos: diseña tus actuadores (2)

¿Cómo harías un ACTUADOR DE PERSIANA?

Un motor de persiana requiere dos fases de alimentación: una para subida y otra para bajada

Se conectaría un relé a una de las fases y otro relé a la otra. Cada relé se controla con un pulsador distinto.

Realiza una simulación con dos LEDs:
Un LED para indicar que el motor está en subida
Un LED para indicar que el motor está en bajada

Es similar al actuador de interruptor pero tiene dos pulsadores (subir y bajar persiana) y dos relés

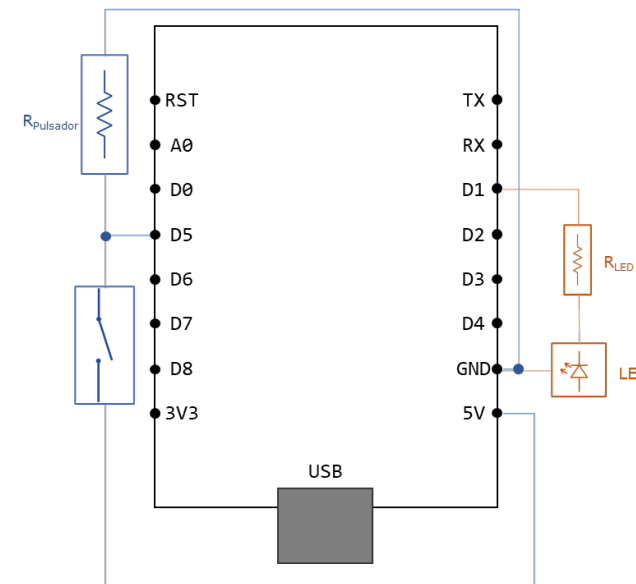

X 2



Se duplican circuitos PERO se puede usar la misma placa ya que quedan pines libres